

TO: All Design Section Staff  
FROM: Amy Leland  
DATE: April 28, 2023  
SUBJECT: WSDOT Scour Countermeasure Design Policy

This design memorandum provides revisions to the WSDOT scour policy in regards to scour countermeasures for new bridges supported by deep foundations. Further guidance is provided that allows the soil protected by the scour countermeasure to remain in place for deep foundation design.

These changes coincide with the latest updates in the Hydraulics Manual, Roadside Manual, and Design Manual.

### Bridge Design Manual Revisions

The following sections of the WSDOT Bridge Design Manual are revised as follows:

#### 7.1.7 Scour Requirements

*The following modifications shall be made to the first four paragraphs of this section.*

Scour can affect the bridge structure, adjacent wall structures, and the bridge embankment. The bridge structure shall be designed for total scour. Total scour for the bridge structure ~~does not~~ may take into account ~~any added~~ scour countermeasures, ~~if certain criteria are met~~, as explained in the sections below. If scour countermeasures are designed and constructed following guidance from the most recent version of ~~HEC-23 the Hydraulics Manual~~, then walls and embankments benefit as explained in the sections below.

All bridge foundations shall be designed for total scour regardless of bridge type, location, and usage. Bridge foundations shall be designed by the bridge designers for total scour considering the following two conditions:

1. At Service and Strength Limit States: For the scour design flood, the streambed material above the total scour line shall be assumed to have been removed for design conditions. ~~The scour design flood is the worst-case scour for all floods up to and including Q100.~~—The Hydraulics Office provides the total scour elevation corresponding to the scour design flood.
2. At Extreme Limit States (Earthquake and Scour): Two separate extreme cases shall be evaluated when verifying the stability of the bridge foundation. ~~The check flood is the worst-case scour for all floods up to and including Q500.~~

- Extreme Case I – 50% of the total scour design flood depth plus seismic
- Extreme Case II – 100% of the total scour check flood depth

### **7.1.7.B Deep Foundations**

*Insert the following after the paragraph starting with “Soil arching conditions behind the shafts shall...”*

The deep foundation abutment (those supported on drilled shafts, piles, or concrete filled steel tubes (CFST)) may be designed assuming the soil protected by the scour countermeasure remains in place if the following conditions are met:

1. Maintenance access is provided from the roadway to the countermeasures. See Roadside Manual 830 for more information related to maintenance access.
2. Rock for Erosion and Scour Protection gradation shall exceed the required gradation by one class.
3. All requirements are met per the Hydraulics Manual.
4. A general note shall be added to the bridge sheets indicating that the deep foundation design assumed the soil protected by the scour countermeasure remains in place.
5. Deep foundations shall extend below the lowest design elevation of the adjacent scour countermeasure at least to a minimum vertical distance that is the greater of 15 feet or 50% of the height between roadway grade near top of abutment and the lowest design elevation of the adjacent scour countermeasure. The bearing pressure under a pile or shaft cap shall not contribute to the resistance of the vertical loads.

If any of these requirements are not met, then the deep foundation shall be designed assuming that the soil above the total scour depth has been removed whether there is a scour countermeasure in place or not.

### **Figure 7.1.7-1**

*Replace Figure 7.1.7-1 with the following:*

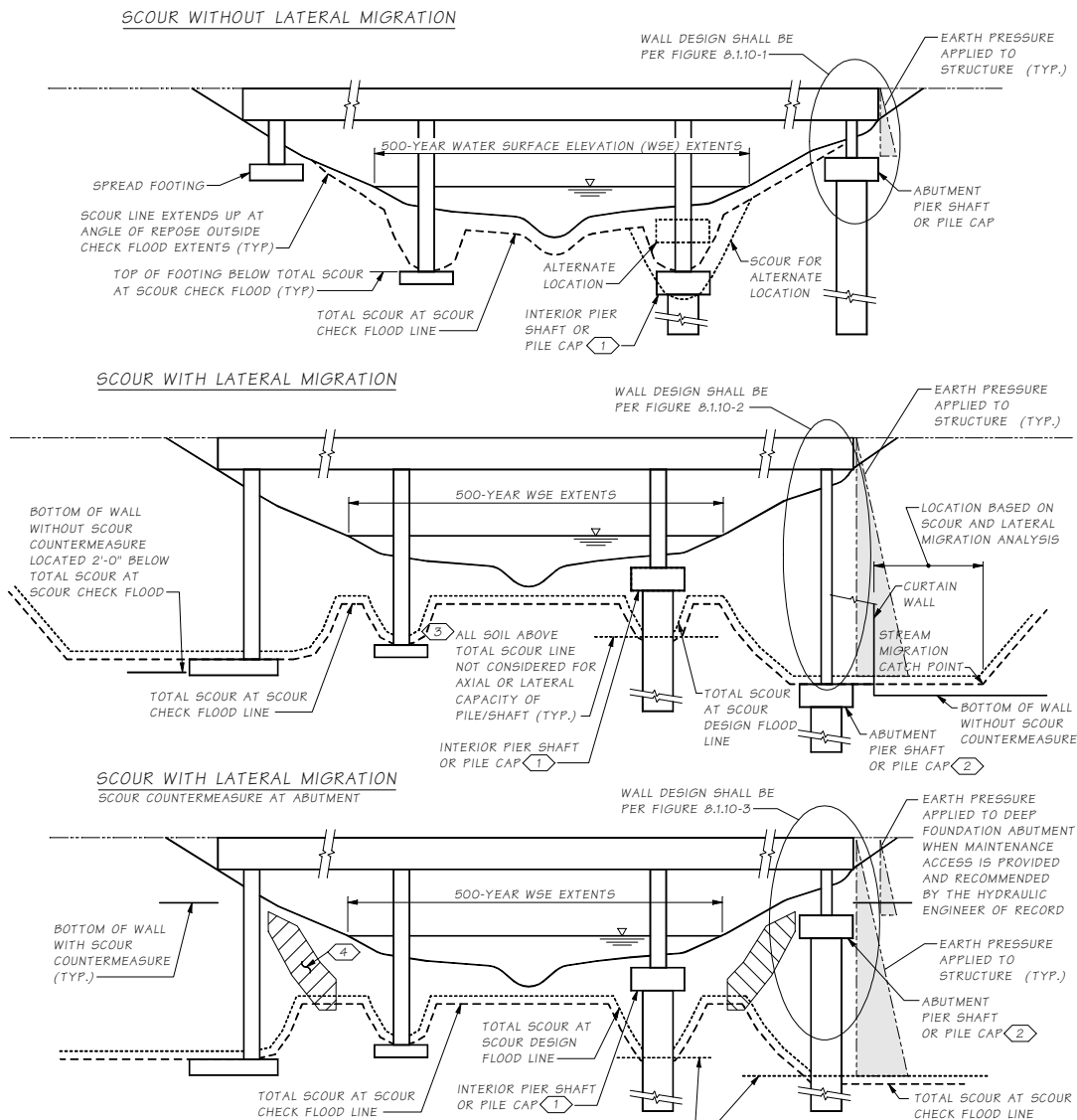

**NOTES:**

- (1) INTERIOR PIER SHAFT OR CAP MAY BE LOCATED ABOVE THE TOTAL SCOUR AT THE SCOUR CHECK FLOOD LINE AS LONG AS THE FOUNDATION IS DESIGNED FOR THIS CONDITION. BOTH HYDRAULIC AND GEOTECHNICAL RECOMMENDATIONS SHALL ACCOUNT FOR THE EXPOSED FOUNDATION GEOMETRY. THE EFFECT OF THE SCOUR PRISM ON THE CAPACITY OF THE SHAFT MAY FOLLOW FIGURE 10-18 OF THE FHWA GECIO MANUAL.
- (2) ABUTMENT PIER SHAFT CAP OR PILE CAP MAY BE LOCATED ABOVE THE TOTAL SCOUR AT THE SCOUR CHECK FLOOD LINE IF A SCOUR COUNTERMEASURE DESIGNED AND CONSTRUCTED FOLLOWING HEC-23 GUIDELINES HAS BEEN ADDED AT THE BRIDGE END AND THE FOUNDATION IS DESIGNED TO ACCOUNT FOR THE CAP BEING LOCATED AT A HIGHER ELEVATION. BOTH HYDRAULIC AND GEOTECHNICAL RECOMMENDATIONS SHALL ACCOUNT FOR THE EXPOSED FOUNDATION GEOMETRY. EARTH PRESSURE ON ABUTMENT SHALL BE PER FIGURE 7.1.7-2. WHEN SCOUR COUNTERMEASURE IS NOT RECOMMENDED TO PREVENT SCOUR BY THE HYDRAULIC ENGINEER OF RECORD OR NO MAINTENANCE ACCESS IS PROVIDED.
- (3) ONLY THE UPPER HALF OF THE TOTAL SCOUR FOR SCOUR DESIGN FLOOD IS IGNORED FOR EXTREME EVENT CASE I.
- (4) COUNTERMEASURES SHALL BE PLACED OUTSIDE THE MINIMUM HYDRAULIC OPENING. LIMITS OF THE COUNTERMEASURE ARE BASED ON SCOUR AND LATERAL MIGRATION ANALYSIS. SCOUR COUNTERMEASURES SHOWN FOR GRAPHICAL PURPOSES ONLY, AND SHALL BE DESIGNED AND CONSTRUCTED PER THE HYDRAULIC MANUAL.

Figure 7.1.7-1

## **Background**

The loads on some of our foundations are very large when evaluating the scoured condition, which results in very expensive and hard to design foundations. Scour countermeasures are placed to help restrict scour. However, scour countermeasures have been known to fail, and there must be confidence that the bridge structure can maintain life safety requirements. Repairs may be needed to the countermeasure and obtaining permits for these repairs without delay is important. By invoking additional requirements to when the scour countermeasures may be counted on to prevent scouring of the abutment risk is reduced.

## **Contact Information**

If you have any questions regarding this policy memorandum, please contact Amy Leland ([lelanda@wsdot.wa.gov](mailto:lelanda@wsdot.wa.gov)) at (360) 705-7181.

cc: Michael Bressan, HQ Construction Office ([bressam@wsdot.wa.gov](mailto:bressam@wsdot.wa.gov))( 7828)