



# Intelligent Transportation Systems (ITS)

Northwest Region

Design requirements

# 2022

December revision

**Page intentionally blank**

# Contents

---

## 1 General requirements

<b>1.1</b>	<b>ITS plan submittals</b>	<b>1</b>
1.1.1	Content and organization	1
<b>1.2</b>	<b>Device naming</b>	<b>4</b>
1.2.1	Naming scheme	4
<b>1.3</b>	<b>Existing ITS devices</b>	<b>7</b>
1.3.1	Operations during construction	7
<b>1.4</b>	<b>Conduit</b>	<b>9</b>
1.4.1	General	9
1.4.2	Size	9
1.4.3	Spare conduits	9
1.4.4	Removal of unused conduit	9
<b>1.5</b>	<b>Junction boxes</b>	<b>10</b>
1.5.1	Type	10
1.5.2	Removal of unused junction boxes	10
1.5.3	Location	10
<b>1.6</b>	<b>Vaults (cable vaults, pull boxes and small cable vaults)</b>	<b>11</b>
1.6.1	Location	11
1.6.2	Removal of unused vaults	12
<b>1.7</b>	<b>Cabling</b>	<b>13</b>
1.7.1	Installation	13
1.7.2	Slack	13
1.7.3	Removal of unused cabling	13
<b>1.8</b>	<b>Cabinets</b>	<b>14</b>
1.8.1	Location	14
1.8.2	Removal of unused cabinets	15
1.8.3	Cabinets on slopes	15
1.8.4	Existing cabinets	15
1.8.5	Power	15
<b>1.9</b>	<b>Cabinet foundations</b>	<b>16</b>
1.9.1	Removal of unused foundations	16
<b>1.10</b>	<b>Type 1 maintenance pullout (pickup truck access)</b>	<b>16</b>
1.10.1	Characteristics	16

1.10.2	Location	16
<b>1.11</b>	<b>Type 2 maintenance pullout (bucket truck access)</b>	<b>16</b>
1.11.1	Characteristics	16
1.11.2	Location	16
<b>1.12</b>	<b>Maintenance access roads</b>	<b>17</b>
1.12.1	Characteristics	17
1.12.2	Location	17
<b>1.13</b>	<b>Work outside of the project limits</b>	<b>18</b>
1.13.1	Cabling	18
1.13.2	Hardware	18
<b>1.14</b>	<b>Special designs</b>	<b>19</b>
1.14.1	Specifications and approval	19

## 2 CCTV

<b>2.1</b>	<b>Overview</b>	<b>20</b>
<b>2.2</b>	<b>CCTV Coverage</b>	<b>21</b>
2.2.1	Coverage and spacing	21
2.2.2	Vegetation	24
2.2.3	Other viewing considerations	24
<b>2.3</b>	<b>Infrastructure</b>	<b>27</b>
2.3.1	Camera	27
2.3.2	Camera pole	27
<b>2.4</b>	<b>Camera cabinet</b>	<b>29</b>
2.4.1	Placement	29

## 3 Loop detection

<b>3.1</b>	<b>Overview</b>	<b>30</b>
<b>3.2</b>	<b>Coverage</b>	<b>30</b>
3.2.1	Mainline	30
<b>3.3</b>	<b>Placement considerations</b>	<b>31</b>
3.3.1	Location for data reliability	31
3.3.2	Additional considerations for Active Traffic Management	31
<b>3.4</b>	<b>Loop naming</b>	<b>32</b>

3.4.1	Naming scheme	32
3.4.2	Maintenance and constructability requirements	35
<b>3.5</b>	<b>Cabinet</b>	<b>36</b>
3.5.1	Location	36
<b>3.6</b>	<b>Equipment</b>	<b>36</b>
3.6.1	Lane width impacts	36
<b>3.7</b>	<b>Loop termination</b>	<b>36</b>
3.7.1	Loop termination schedule	36

## 4 Ramp metering

<b>4.1</b>	<b>Overview</b>	<b>37</b>
<b>4.2</b>	<b>Coverage</b>	<b>37</b>
4.2.1	Coverage area	37
<b>4.3</b>	<b>Stop line location</b>	<b>38</b>
4.3.1	Minimum stop line distance to merge	38
4.3.2	Maximum stop line distance to merge	39
4.3.3	Storage capacity	40
4.3.4	Number of metered lanes	42
4.3.5	Using the shoulder as storage	42
<b>4.4</b>	<b>Cabinets</b>	<b>43</b>
4.4.1	Cabinet type	43
4.4.2	Additional cabinet placement considerations for ramp metering	43
<b>4.5</b>	<b>Loop detection requirements</b>	<b>43</b>
4.5.1	Installation	43
4.5.2	Coverage	44
<b>4.6</b>	<b>Ramp meter signal pole</b>	<b>46</b>
4.6.1	Location	46
4.6.2	Ramp Meter Signal Standard (Type 1 Ramp Meter Pole)	46
4.6.3	Overhead Ramp Meter Signal Standard (Type 2 Ramp Meter Pole)	46
<b>4.7</b>	<b>Advance Warning Sign and Beacon (AWS)</b>	<b>49</b>
4.7.1	Placement	49

4.7.2	Sign details	50
<b>4.8</b>	<b>Other requirements</b>	<b>50</b>
4.8.1	Emergency vehicles	50

## 5 Variable Message Signs

<b>5.1</b>	<b>Overview</b>	<b>51</b>
<b>5.2</b>	<b>Standalone variable message sign</b>	<b>51</b>
5.2.1	Location	51
5.2.2	Mounting	53
5.2.3	Cabinet	53
5.2.4	Standalone VMS specification	54
<b>5.3</b>	<b>Active Traffic Management sites</b>	<b>55</b>
5.3.1	Installation location	55
5.3.2	Lane control signs (LCS)	57
5.3.3	Lane control sign specification	57
5.3.4	Side-mounted signs (SMS)	58
5.3.5	Side-mounted sign specification	58
5.3.6	ATM Variable Message Signs (VMS)	59
5.3.7	ATM full-size VMS specification	59
5.3.8	ATM small VMS specification	59

## 6 Other ITS devices

<b>6.1</b>	<b>HAR</b>	<b>60</b>
6.1.1	General	60
6.1.2	HAR sign (HARS) location	60
6.1.3	HAR transmitter (HART) location	60
6.1.4	Cabinet	60
<b>6.2</b>	<b>Environmental Sensor Station (ESS)</b>	<b>60</b>
6.2.1	Location	61
6.2.2	Cabinet	61
<b>6.3</b>	<b>Uninterruptable Power Supply (UPS)</b>	<b>61</b>
6.3.1	Conduit	61

## 7 Temporary ITS

<b>7.1</b>	<b>Overview</b>	<b>62</b>
<b>7.2</b>	<b>General</b>	<b>62</b>
7.2.1	Operations	62
<b>7.3</b>	<b>Communication systems</b>	<b>62</b>
7.3.1	Exposure to traffic	62
<b>7.4</b>	<b>CCTV</b>	<b>63</b>
7.4.1	Coverage during construction	63
<b>7.5</b>	<b>Ramp meters</b>	<b>63</b>
7.5.1	Operations	63
<b>7.6</b>	<b>Temporary vehicle detection</b>	<b>63</b>
7.6.1	Type and location	63

## 8 Communications

<b>8.1</b>	<b>Overview</b>	<b>64</b>
<b>8.2</b>	<b>Communication hub</b>	<b>65</b>
8.2.1	Description	65
8.2.2	Location	65
8.2.3	Existing communication hubs	65
8.2.4	Exterior treatment	65
<b>8.3</b>	<b>Conduit</b>	<b>66</b>
8.3.1	Location	66
8.3.2	Size	67
8.3.3	Contents of conduits	68
8.3.4	Existing infrastructure	69
8.3.5	Crossings	70
<b>8.4</b>	<b>Vaults</b>	<b>71</b>
8.4.1	General requirements	71
8.4.2	Cable vaults	71
8.4.3	Pull boxes	71
8.4.4	Small cable vaults	71
<b>8.5</b>	<b>Mainline cabling</b>	<b>72</b>
8.5.1	Description	72
8.5.2	General requirements	72
8.5.3	Cable termination	72
<b>8.6</b>	<b>Distribution cabling</b>	<b>73</b>
8.6.1	Description	73

8.6.2	General requirements	73
8.6.3	Strand usage	73
8.6.4	Route architecture	73
8.6.5	Cable termination	74
<b>8.7</b>	<b>Lateral cabling</b>	<b>76</b>
8.7.1	Description	76
8.7.2	General requirements	77
8.7.3	Cable termination	77
<b>8.8</b>	<b>Interconnect cabling</b>	<b>78</b>
8.8.1	Description	78
8.8.2	General	78
8.8.3	Cable termination	78
<b>8.9</b>	<b>Fiber optic patch cords</b>	<b>78</b>
8.9.1	General requirements	78
<b>8.10</b>	<b>Other requirements for cabling</b>	<b>79</b>
8.10.1	General requirements	79
<b>8.11</b>	<b>Communications Equipment</b>	<b>79</b>
8.11.1	Roadside cabinets	79
8.11.2	Communication hubs	80
8.11.3	Traffic management center	81

## 9 ITS for roundabouts

<b>9.1</b>	<b>CCTV</b>	<b>82</b>
9.1.1	Location	82
<b>9.2</b>	<b>Loop detection</b>	<b>82</b>
9.2.1	Data station	82
9.2.2	Loops on entering lanes	82
9.2.3	Loops on exit lanes	82
<b>9.3</b>	<b>Communication</b>	<b>82</b>
9.3.1	Connection to WSDOT network	82
<b>9.4</b>	<b>ITS configuration</b>	<b>83</b>
9.4.1	Naming and location	83



# 1 General requirements

---

## 1.1 ITS plan submittals

### 1.1.1 Content and organization

The goal of any ITS designer is to assemble a comprehensive set of plans that includes a thorough and purpose-built ITS network that will optimize roadway operations. A good design results in a complete, fully-functional and maintainable ITS network.

ITS plans must include all the information necessary for a complete review of the work being performed. They must also include all the information required for construction or installation, and for documentation of the completed work for future reference.

1.1.1.1 ITS plans shall contain each of the following if relevant to the project (e.g. patch panel layout details are not relevant if there are no patch panels in the project):

- Title block, north arrow and scale bar;
- Legend of symbols;
- Existing ITS features and utilities, including device ID;
- Existing and new loop names;
- Proposed channelization;
- Temporary ITS plans, ITS details, construction notes and wire notes;
- Permanent ITS plans, ITS details, construction notes and wire notes;
- Toll infrastructure;
- Fiber optic splice details;
- Patch panel layout details;
- Communication schematic, including all equipment and IP address information, and fiber assignment numbers (see **Figure 1-1: Example communication schematic**);
- One-line fiber distribution diagram (see **Figure 1-2: Example one-line diagram and patch panel layout**);
- Hub details including elevation views of the new and existing equipment installed in the racks;
- Detail sheets for loops, cabinets, CCTV, etc.;
- Details for all non-standard installations and elements;
- All other information needed or required elsewhere to properly document the work being done.

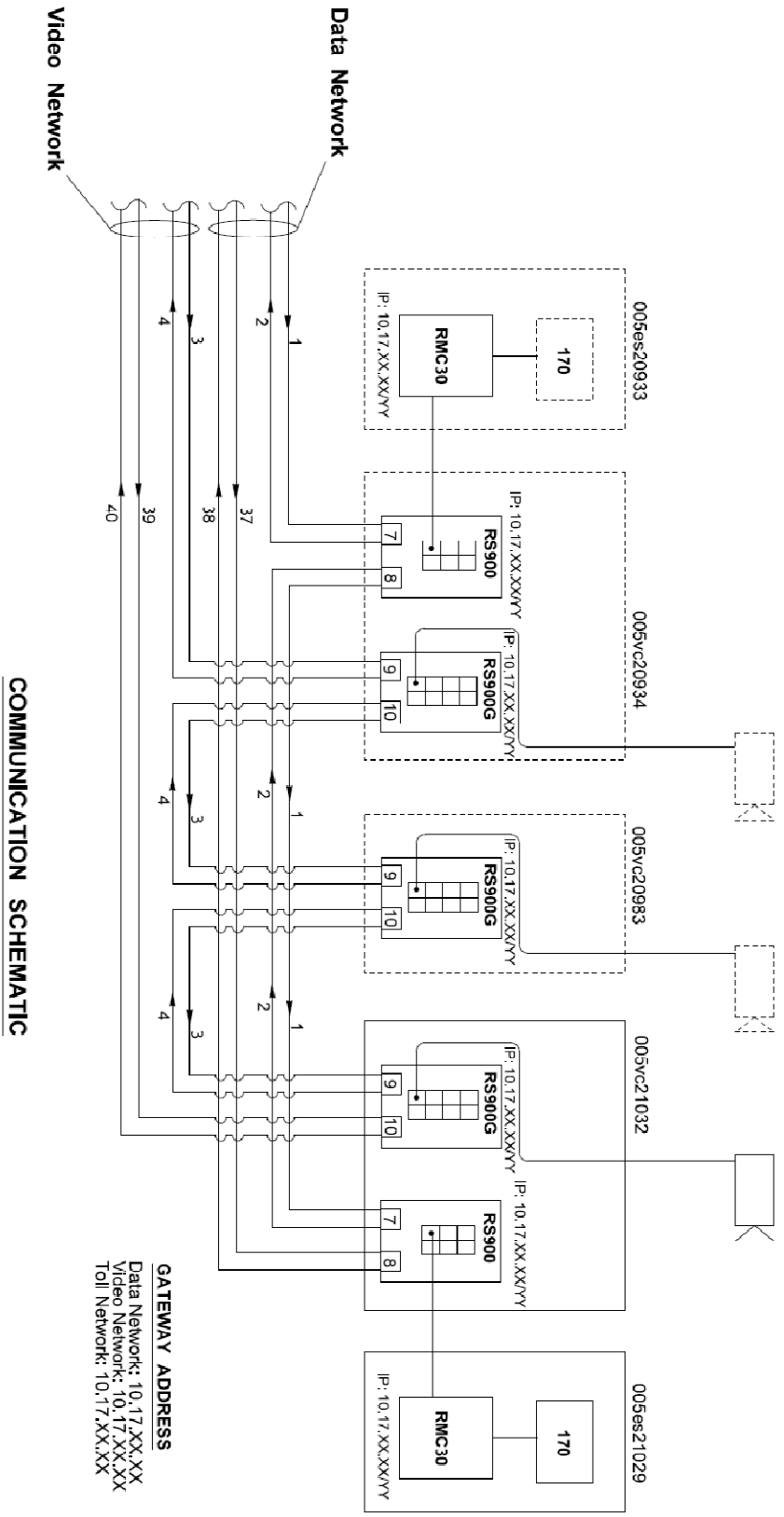

Figure 1-1: Example communication schematic



- 1.1.1.2 Wire notes, construction notes and the ITS legend shall be on separate sheets from the plan sheets.
- 1.1.1.3 Temporary ITS plans, construction notes and wire notes shall be on separate plan sheets from the permanent plan sheets.
- 1.1.1.4 All new and existing ITS and spare conduits shall be shown on both the detail sheets the plan sheets.
- 1.1.1.5 All conduits shown in a detail shall be identified with wire notes. Where these conduits cross the detail boundary they shall be identified both within the detail and on the plan sheet outside of the detail boundary.
- 1.1.1.6 Tolling detail sheets shall be separate from ITS plan and detail sheets.
- 1.1.1.7 The tolling plan shall be shown on the ITS plan sheets.
- 1.1.1.8 All non-ITS work shall be on separate plan sheets.

## 1.2 Device naming

### 1.2.1 Naming scheme

ITS devices must be named using a consistent system in order to reduce confusion and improve device management. Inconsistent naming will introduce inaccuracies when communicating within the agency or with contractors, which will lead to maintenance and construction errors.

The name consists of 3 concatenated fields:

- A 3-digit roadway number with zeroes prepended to the beginning of the number for roadway numbers with fewer than 3 digits (e.g. 005, 090, 405);
- A 2-character device type code as shown in Table 1-1;
- A 5-digit milepost at which the device itself is located, reflecting the nearest 1/100<sup>th</sup> mile with the decimal point removed (i.e., 165.37 becomes 16537). Use SRMP (State Route Milepost) when determining milepost instead of ARM (Accumulated Route Mile).

For example, a variable message sign on I-90 at milepost 11.19 will be named 090vm01119.

Note that the 5-digit milepost used in the device name reflects the location of the device itself, not the location of its corresponding cabinet. For a camera, the milepost represents the location of the camera. For a data station or ramp meter, the milepost represents the location of the mainline loops. If the mainline loops for each location are not aligned at the same location, the average milepost between the separate locations is used instead. For a data station at a roundabout, use the milepost of the center of the roundabout. For a VMS or HARS cabinet, the milepost for the sign is used. For a transformer cabinet, the location of the transformer cabinet itself is used. WSDOT's *GeoPortal* is a useful tool for determining the milepost of a device.

Device names must also be unique and cannot be duplicated. In situations where multiple devices of the same type are placed at the same milepost, such as lane control signs for an ATM installation, the milepost of the device name may be adjusted by 1/100<sup>th</sup> mile to create a unique name. The milepost stated within the device name must increase from right to left when facing the direction of increasing milepost. The device closest to the median, or the device to the right of the median if they are equidistant, will use the actual milepost for its device name.

- 1.2.1.1 The device name shall consist of 3 concatenated fields: (1) roadway number, (2) type code and (3) milepost.
- 1.2.1.2 The roadway number within the device name shall contain 3 digits. Zeroes are prepended to the beginning of the roadway number for roadway numbers with fewer than 3 digits.
- 1.2.1.3 The type code within the device name shall be 2 characters, following the naming scheme shown in **Table 1-1: Type codes**.
- 1.2.1.4 The milepost within the device name shall contain 5 digits, reflecting the location of the ITS device itself, not its cabinet unless the mileposts are the same, to the nearest 1/100<sup>th</sup> mile with the decimal point removed. Zeroes are prepended to the beginning of the milepost to meet the 5-digit requirement if necessary. SRMP shall be used when determining the milepost.

Device	Type Code	Device	Type Code
ATM Corridor	ac	Neon Sign	ns
Call Box	cb	electrical Power Service	ps
communication HuB	hb	earthQuake Detector	qd
Changeable Message sign	cm	earthQuake Processor	qp
Closure Signal	cs	Reversible Controller	rc
closed circuit Video Camera	vc	toll Rate Sign	rs
Drum Sign	ds	Seismic gate Controller	sc
Ramp Meter / Data Station	es	Security Device	sd
Toll Facility	fc	variable Speed Limit sign	sl
Flashing Beacon	fb	toll Tag Reader	tr
Fiber optic Terminal cabinet	ft	Terminal Cabinet	tc
Gate Controller	gc	roadside Toll cabinet	tl
ATM Gantry	gn	Toll triP	tp
HAR Sign	hs	Traffic Signal	ts
HAR Transmitter	ht	Travel Time sign	tt
Illumination Control	ic	UPS	up
Information Side-Mount & Speed sign	is	Variable Message sign	vm
Lane Control sign	lc	Weather Station (RWIS)	ws
License plate Reader	lr	Weigh-in-moTion (CVISN)	wt
Movable Gate	mg	Transformer	xf
Microwave Repeater	mr		

**Table 1-1: Type codes**

- 1.2.1.5 Each device shall receive a unique device name, even if they are the same type of device at the same location.
- 1.2.1.6 If multiple devices of the same type are installed at the same milepost, the milepost within the device name shall be adjusted by 1/100<sup>th</sup> mile to satisfy the name uniqueness requirement. The milepost stated within the device shall increase from right to left across the entire roadway, when facing the direction of increasing milepost.
- 1.2.1.7 If multiple devices of the same type are installed at the same milepost, the device closest to the median, or the device to the right of the median if they are equidistant, shall use the actual milepost within its device name. See **Figure 1-3: Example of lane control sign names on state highway** for graphical explanation.

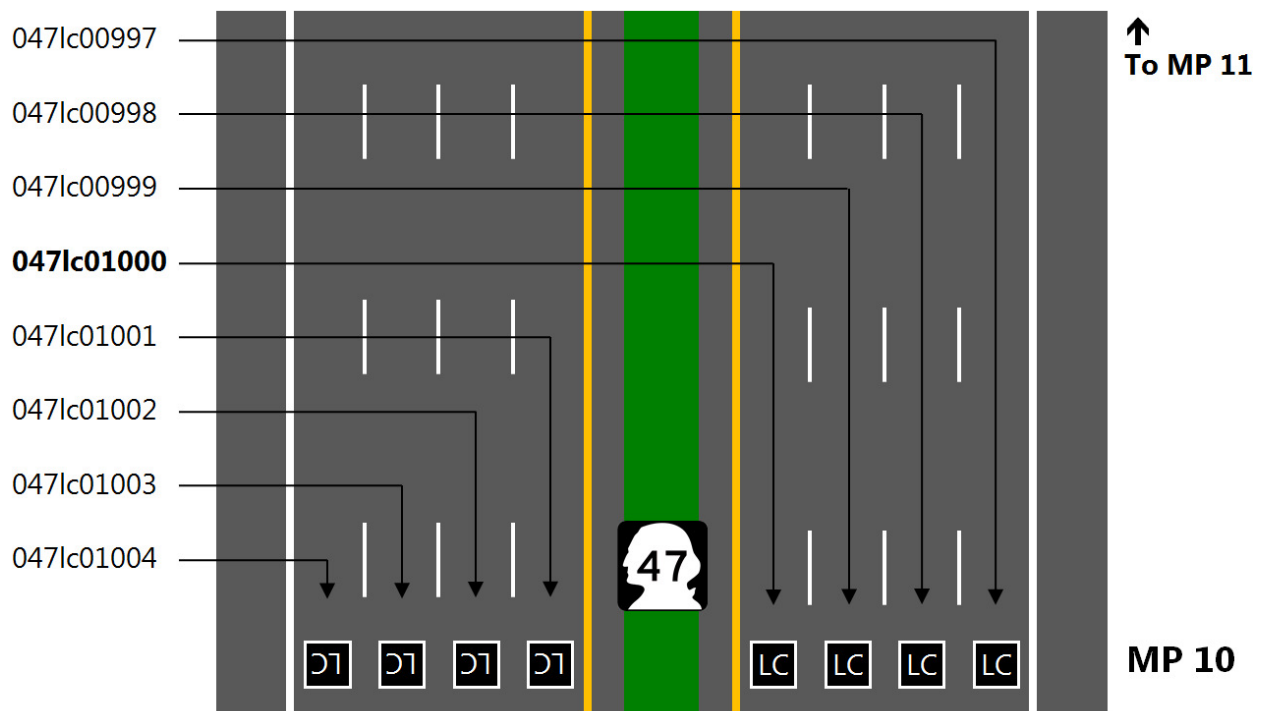

**Figure 1-3: Example of lane control sign names on state highway 47**

## 1.3 Existing ITS devices

### 1.3.1 Operations during construction

Whenever work is performed on an existing ITS device, the existing device will most likely experience operational impacts. These devices and the impacts to the devices must be stated clearly in the special provisions. Examples of these situations are included below:

- If the grinding process during a paving project will impact induction loops embedded in the pavement, a disruption specification must state the maximum duration of time that the loops can remain out of normal operations. This must be limited to the amount of time actually required to perform the work (typically 1 to 5 days).
- If power is interrupted to a device, it should only occur when the device is least needed. This may be in the middle of the day, but it is usually in the middle of the night. It may be acceptable to keep a device out of operations for an extended period of time if impacts are minimal or if alternatives are unrealistic, but there must be a clearly stated limit in the special provisions.

Specifications regarding temporary ITS equipment and disruptions to existing devices are often the most difficult to write. These specifications explain to the contractor the work they must perform prior to an impact, the work to be performed during the impact/cutover and/or the maximum allowed duration of impact to the system. It is crucial to consider all aspects of the cutover and to verify that the work can be accomplished in the allotted time. Complex projects may have disruption specifications that are several pages long. Some examples of disruption specifications are included below.

#### **ITS Loops**

The Contractor shall have 3 consecutive calendar days to install and make functional all new loops from the time that existing loops are ground, damaged or otherwise disrupted by construction activities.

The Contractor shall not disrupt more than 3 mainline loop installations at any given time. A mainline loop installation is defined as a set of count and speed loops installed in all lanes at a single location and tied to a single cabinet.

Failure to meet the 3 day deadline will result in the assessment of liquidated damages in accordance with the subsection **Liquidated Damages** of the Special Provision **PROSECUTION AND PROGRESS**.

#### **005es18252 Temporary Ramp Meter**

The Contractor shall install and make operational a temporary ramp meter system for the existing ramp meter 005es18252 as shown in the plans within 5 calendar days after the traffic shift on the W-S ramp. The temporary ramp meter shall remain operational until 005es18236 and all associated loops are operational and connected to the WSDOT TMC in Shoreline.

Failure to install the temporary ramp meter as outlined above will result in the assessment of liquidated damages in accordance with the subsection **Liquidated Damages** of the Special Provision **PROSECUTION AND PROGRESS**.

### **Video and Data Communication Cutover**

The contractor shall have one weekend between the hours of 8 PM Friday and 4 AM Monday to cutover the video and data communication system. Work to be completed before the cutover includes splicing and terminating a new 36 SMFO between the Everett HUB and 005vc18726. On the cutover weekend the contractor shall connect the fiber optic facility as to allow video and data communication to 005vc18726, 005vc18748, 005vc18797, and 005vc18848. Lateral data communication shall also be established to 005es18726, 005vm18726, 005es18739, 005es18789, 005es18846, and 005es18847. Work to be completed prior to the cutover weekend shall include:

- The new 005vc18748 shall be installed in accordance with the plans.
- The 36 SMFO cable, all distribution cables, all SMFO electronics, and all patch panels shall be installed and connected between the Everett HUB and 005vc18726 as shown in the plans.
- Install and connect the RS-900 Ethernet switch in the Everett HUB.
- Program all Ethernet devices as shown in the plans and test the data network for connectivity.

The following work shall occur on the cutover weekend:

- Connect the Ethernet devices to all 170 and VMS controllers.
- Connect the camera feed and control to the fiber optic transmitter.

Failure to meet the 4 AM Monday deadline will result in the assessment of liquidated damages in accordance with the subsection **Liquidated Damages** of the Special Provision **PROSECUTION AND PROGRESS**.

### **Mainline Communication Cutover**

The contractor shall have one weekend between the hours of 8 PM Friday and 4 AM Monday to cutover the mainline communication cable. The following work items shall be completed before the cutover weekend:

- Install 1-60 SMFO cable between the Everett HUB and the cable vault at STA LRC 819+20.
- Splice the 1-60 SMFO to the pre-terminated patch panel in the Everett HUB.

The work shall occur in the following order:

1. Cut the existing 1-60 SMFO cable in the cable vault at STA LRC 819+20.
2. Splice the new 1-60 SMFO cable from the Everett HUB to the existing 1-60 SMFO mainline communication cable.
3. Remove the disconnected 1-60 SMFO cable between the Everett HUB and the cable vault at STA LRC 819+20.

Failure to meet the 4 AM Monday deadline will result in the assessment of liquidated damages in accordance with the subsection **Liquidated Damages** of the Special Provision **PROSECUTION AND PROGRESS**.

- 1.3.1.1 Any device or component that will be impacted shall be stated in the special provisions, including the expected duration of impact.
- 1.3.1.2 All existing ITS devices shall be kept operational during the project unless the existing device has already been replaced with a new one that has been inspected and made fully operational by WSDOT.
- 1.3.1.3 Once a new device has replaced an existing ITS device and has been inspected by WSDOT, the new device shall be kept operational.
- 1.3.1.4 Devices that are damaged by construction activities that are not specifically designated for replacement or removal in the plans or the RFP shall be restored to new condition or replaced by the Contractor in accordance with WSDOT standards.

## 1.4 Conduit

### 1.4.1 General

- 1.4.1.1 Conduits between cabinets on a shared foundation shall not go through any junction boxes.

### 1.4.2 Size

- 1.4.2.1 The minimum size of conduits for Intelligent Transportation Systems (ITS) shall be 2" in diameter. However, a smaller conduit may be used at Type 1 (RM & FB) pole foundations and for power conduits between cabinets and transformers.

### 1.4.3 Spare conduits

- 1.4.3.1 A minimum of one spare 2" conduit is required at each roadway crossing.
- 1.4.3.2 A minimum of one spare 2" conduit is required through VMS structure foundations.
- 1.4.3.3 A minimum of one spare 2" conduit is required between each transformer cabinet and its nearest junction box.
- 1.4.3.4 A minimum of one spare 2" conduit is required between each device cabinet and its nearest junction box/cable vault with the following additional requirements:
  - ES cabinets require two 2" or one 3" spare conduit(s);
  - Foundations installed for future cabinets require a minimum of three 2" conduits or two 3" conduits, in addition to one 2" conduit to the adjacent ITS cabinet with the patch panel and one conduit to the transformer.

### 1.4.4 Removal of unused conduit

- 1.4.4.1 Surface-mounted ITS conduits that are abandoned as part of the project shall be removed.

## 1.5 Junction boxes

### 1.5.1 Type

1.5.1.1 Any existing type 3 junction box shall be replaced with a heavy-duty type 6 junction box if located in pavement or a type 8 junction box if not located in the pavement.

1.5.1.2 If an existing junction box is located in the paved shoulder, it shall be replaced with a heavy-duty junction box.

### 1.5.2 Removal of unused junction boxes

1.5.2.1 Any ITS junction boxes that are not part of the permanent ITS network when the project is complete shall be removed.

### 1.5.3 Location

1.5.3.1 All existing junction boxes that are in, or are within 3 feet of, the existing or proposed travelled way shall be moved to a location outside of the pavement whenever possible. If relocating outside the pavement is not possible, the junction boxes shall be moved to a location 3 feet or more outside of the travelled way and replaced with a heavy-duty junction box (type 4, 5 or 6) or a pull box with a heavy-duty lid.

1.5.3.2 Any new junction box shall be located outside of the pavement whenever possible. If a location outside the pavement is not possible, any junction box in pavement shall be a heavy-duty junction box (type 4, 5 or 6) or a pull box with a heavy-duty lid and be located 3 feet or more away from the travelled way. For narrow shoulder applications next to barrier, NEMA boxes in the barrier may be used.

1.5.3.3 Any junction boxes not located in the pavement shall not be heavy duty junction boxes.

## 1.6 Vaults (cable vaults, pull boxes and small cable vaults)

### 1.6.1 Location

- 1.6.1.1 A cable vault shall be located adjacent to all device cabinet foundations. This vault shall be used to collect and distribute all field wiring to the adjacent ITS cabinets (including ramp meter signal wires, but not including device power supply wires to VMS, DMS, TRS, etc. or cabinet power supply wiring). This vault shall also house the distribution fiber splice. However, the mainline conduit system may not pass through this vault; if the mainline conduit system is routed next to this cable vault, a pull box shall be installed for the mainline conduit system with a conduit connection to this cable vault for the distribution fiber connection.
- 1.6.1.2 Small cable vaults shall not be installed in pavement as they are not rated for heavy duty use.
- 1.6.1.3 All existing vaults that are in, or are within 3 feet of, the existing or proposed travelled way shall be moved to a location outside of the pavement whenever possible.
  - 1.6.1.3.1 If relocating outside the pavement is not possible, cable vaults and pull boxes shall be moved to a location where the nearest edge of the vault is 3 feet or more outside of the travelled way. Small cable vaults that contain a splice shall be moved and replaced with a heavy duty cable vault, and small cable vaults that do not contain a splice shall be moved and replaced with a heavy duty pull box.
- 1.6.1.4 Any pull box or cable vault that is not located in the pavement shall be supplied with a standard-duty lid.
- 1.6.1.5 Any pull box or cable vault that is located in the pavement shall be supplied with a heavy-duty lid. In cases where an existing standard lid is to be replaced with a heavy-duty lid, the existing pull box or cable vault shall be analyzed to ensure it can support the same loading as the heavy-duty lid.
- 1.6.1.6 The top of all vaults connected directly to a cabinet foundation shall have the same elevation as, or a lower elevation than, the cabinet foundation.

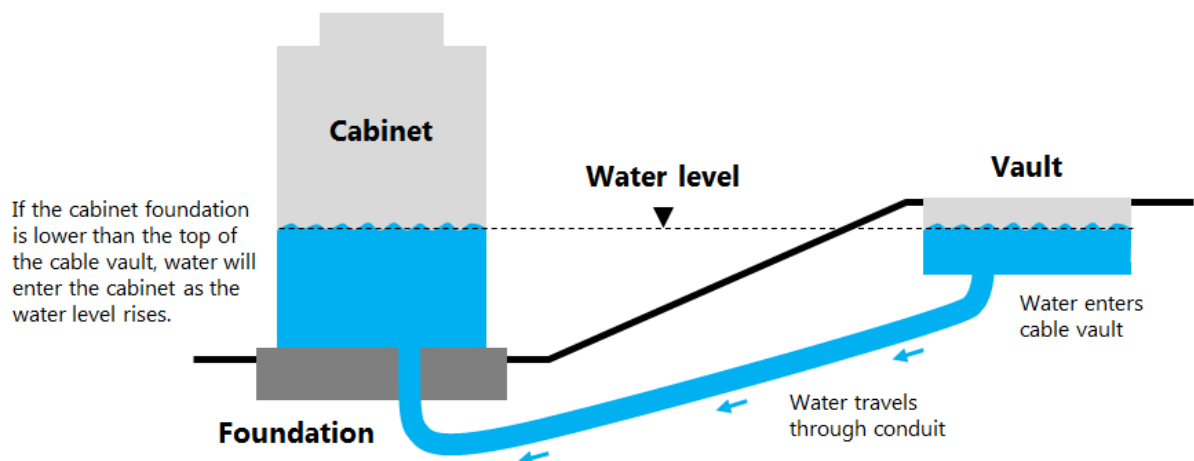

Figure 1-4: Cabinet foundation height requirements in relation to vaults

- 1.6.1.7 New and existing cable vaults and pull boxes shall not be located in a traveled lane under any circumstances.
- 1.6.1.8 Unless approved by WSDOT, new and existing cable vaults and pull boxes shall be located outside of the pavement. If approved for use in the paved shoulder, the following requirements shall be met:
- The cable vaults and pull boxes shall be equipped with heavy-duty lid if located in the shoulder;
  - The nearest edge shall be no less than 3 feet from the edge stripe.
- 1.6.1.9 If the lids of new or existing cable vaults and pull boxes need to be adjusted upwards to match new grading or pavement surface, a maximum of two risers may be utilized for this purpose. If the needed upward lid elevation adjustment exceeds 1 foot then the entire cable vault or pull box and all associated conduits need to be raised.
- 1.6.2 Removal of unused vaults**
- 1.6.2.1 Any vaults that are not part of the permanent ITS network when the project is complete shall be removed.
- 1.6.2.2 Abandoned conduits shall be removed from all vaults and the resulting hole shall be grouted to match the surrounding surfaces.

## 1.7 Cabling

### 1.7.1 Installation

1.7.1.1 Cables supplying power to cabinets shall only share conduits and junction boxes with other power or illumination circuits.

1.7.1.2 Cabling shall not use cabinets as a raceway or junction box. If a cable is not intended for use in a cabinet, it shall not be installed into or through that cabinet.

### 1.7.2 Slack

1.7.2.1 All vaults must contain a minimum of 50 feet of slack for each fiber optic cable. In some situations, more slack may be required.

1.7.2.2 50 feet of slack shall be provided for each direction of every cable entering a splice closure.

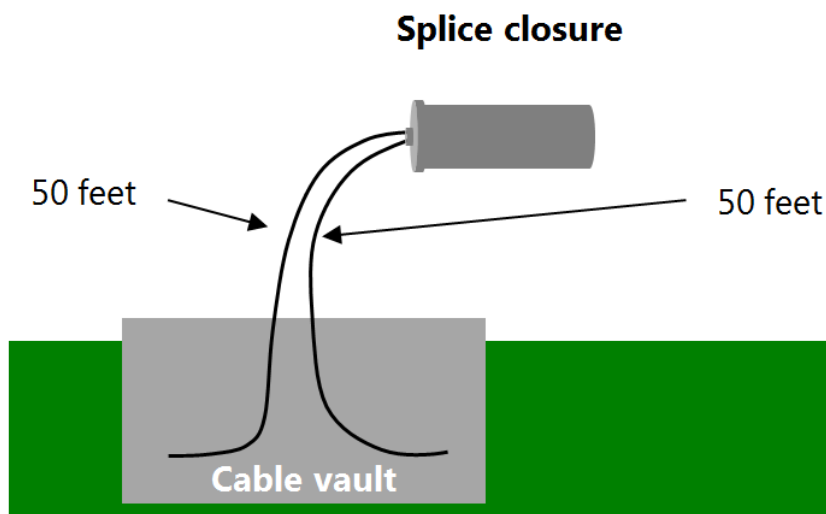

**Figure 1-5: Splice closure and cable slack**

1.7.2.3 Sufficient slack shall be added to reach the locations of any devices that are being installed within 2 years of contract completion and where the total extra slack does not exceed 600 feet.

### 1.7.3 Removal of unused cabling

1.7.3.1 Any cables in ITS conduits that are not part of the permanent ITS network when the project is complete shall be removed.

# 1.8 Cabinets

## 1.8.1 Location

1.8.1.1 Cabinets shall be located where they are accessible from WSDOT roadways.

1.8.1.2 Cabinets shall be no closer than 8 feet from the face of nearby guardrails. This is to accommodate the deformable nature of guardrails upon impact. If the cabinets are placed too close to the guardrail, it is likely that they, or the personnel working with the cabinets, will be struck as a result of guardrail deflection, as shown in the adjacent photo. This particular incident damaged variable speed and lane control cabinets, resulting in over a month of outage and substantial replacement costs.



Figure 1-6: Cabinet damage due to guardrail deflection

1.8.1.3 Cabinets shall be no closer than 5 feet from the face of a non-rigid concrete barrier.

1.8.1.4 Sufficient length of barrier shall be provided to protect both the cabinets and the work area around the cabinets according to the design manual.

1.8.1.5 In addition to any clear zone requirements identified in the design manual, any cabinet closer than 15 feet to the edge of pavement on the outside of a curve along an on-ramp or exit ramp shall be installed behind guardrail or concrete barrier.

1.8.1.6 The elevation of the top of a cabinet foundation shall not be lower than the top of any adjacent junction box or vault connected to the foundation with conduit. This is to prevent water from draining from the junction box into the cabinet.

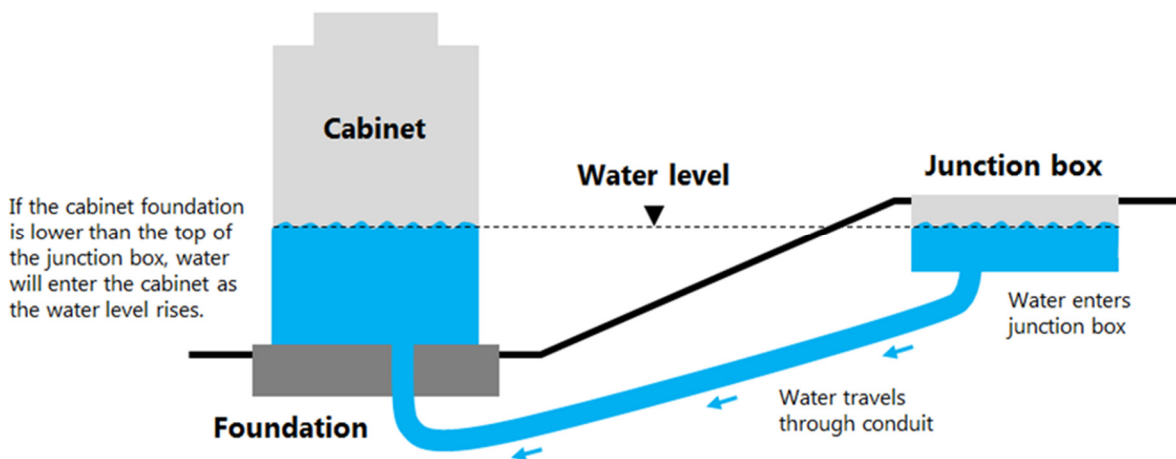

Figure 1-7: Cabinet foundation height requirements in relation to junction boxes

- 1.8.1.7 Cabinets shall not be placed behind any structural or noise/sound walls. This is to facilitate maintenance access.
- 1.8.1.8 ITS devices shall not share the same cabinet with any other systems unless the cabinet is a WSDOT-standard multi-use cabinet specifically designed for that purpose (i.e. 332D with CCTV). This includes, but is not limited to, signals, illumination, irrigation, etc.
- 1.8.1.9 ES cabinets shall not be used to house equipment for any other system, including other ITS systems. This is to prevent crowding as ES cabinets are very full. Adding additional equipment will block access to other cabinet components.
- 1.8.2 Removal of unused cabinets**
- 1.8.2.1 Any cabinets that are not part of the permanent ITS network when the project is complete shall be removed.
- 1.8.3 Cabinets on slopes**
- 1.8.3.1 For slopes uphill from the roadway the foundation shall be cut into the hillside according to the ITS detail for sloped foundations.
- 1.8.3.2 For slopes downhill from the roadway equal to or flatter than 4:1, the foundation shall be cut into the hillside according to the ITS detail for sloped foundations.
- 1.8.3.3 For slopes downhill from the roadway, steeper than 4:1, the following features are required:
- A retaining wall shall be built and a platform constructed between the roadway and the retaining wall to support the ITS cabinet foundation;
  - The ITS cabinet foundation shall be at the same elevation as the roadway;
  - A fence shall be provided around the perimeter of the raised platform according to Standard Plan L-20.10;
  - The distance between the fence and the sides of the cabinet shall be no less than 3 feet;
  - The distance between the fence and either door of the cabinet shall be no less than 5 feet.
- 1.8.4 Existing cabinets**
- 1.8.4.1 Existing cabinets within the project limits shall be replaced if any of the following conditions are met:
- The cabinet is designated for replacement in the contract documents;
  - The cabinet is more than 20 years old before Notice to Proceed (NTP) for the project is issued;
  - The cabinet does not meet current NWR ITS specifications;
  - The cabinet is damaged.
- 1.8.4.2 Existing cabinet foundations within the project limits shall be replaced if a new cabinet is being installed and the existing foundation does not meet all design requirements for a new foundation, including conduit requirements.
- 1.8.5 Power**
- Each ITS cabinet shall be on its own circuit, with its own circuit breaker and power cables from either the transformer or the service cabinet feeding it.

## 1.9 Cabinet foundations

### 1.9.1 Removal of unused foundations

1.9.1.1 Any foundations that are not part of the permanent ITS network when the project is complete shall be removed.

1.9.1.2 Cabinets shall use the same foundation as other nearby cabinets when possible.

## 1.10 Type 1 maintenance pullout (pickup truck access)

### 1.10.1 Characteristics

1.10.1.1 Type 1 maintenance pullouts shall have these minimum characteristics:

- 8-foot wide, 80-foot long paved shoulder;
- 5:1 entrance taper;
- 30:1 exit taper.

### 1.10.2 Location

1.10.2.1 Type 1 maintenance pullouts are required next to all cabinet and hub locations.

## 1.11 Type 2 maintenance pullout (bucket truck access)

### 1.11.1 Characteristics

1.11.1.1 For pullouts next to camera poles, a minimum of 30 feet of the pullout shall be located downstream of the camera pole and a minimum of 10 feet of the pullout shall be located upstream of the camera pole.

1.11.1.2 For pullouts next to structures with a VMS, a minimum of 35 feet of the pullout shall be upstream of the structure.

1.11.1.3 Type 2 maintenance pullouts shall have these minimum characteristics:

- 14-foot wide, 50-foot long paved shoulder;
- 35:1 entrance taper;
- 70:1 exit taper.

### 1.11.2 Location

1.11.2.1 Type 2 maintenance pullouts shall be provided next to all poles with cameras mounted on them.

1.11.2.2 Type 2 maintenance pullouts shall be provided next to all structures with a walk-in VMS.

1.11.2.3 Part time-use shoulder lanes (PUSL) and metered shoulders shall not be considered for use as maintenance pullouts.

## 1.12 Maintenance access roads

### 1.12.1 Characteristics

1.12.1.1 Maintenance access roads shall have these minimum characteristics:

- The access road shall be provided to the nearest WSDOT roadway shoulder;
- The road shall be a minimum of 14 feet wide;
- The road shall be constructed according to the detail in **Figure 1-8: Maintenance access road**;
- A 10' wide x 15' long generator parking pad shall be provided adjacent to the hub transfer switch and connected to the access road.

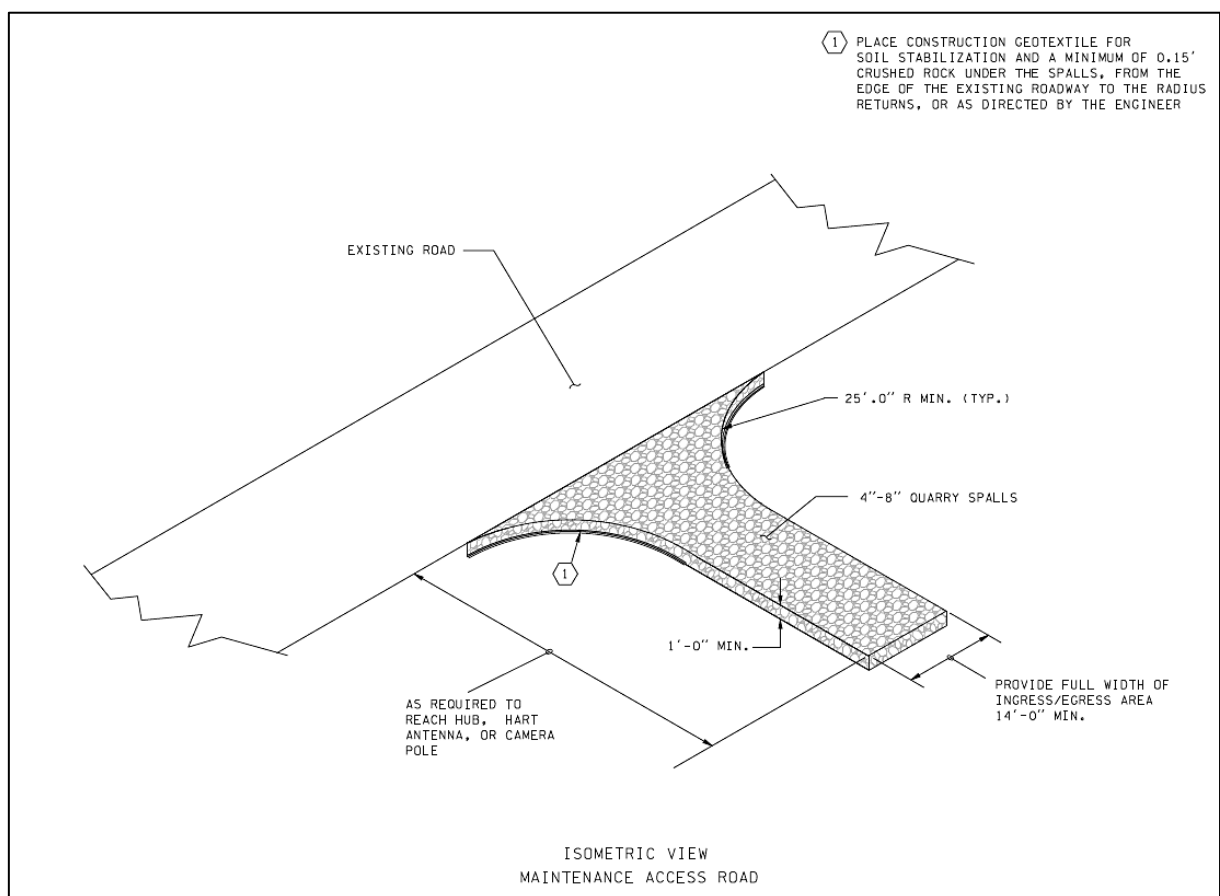

**Figure 1-8: Maintenance access road**

### 1.12.2 Location

1.12.2.1 Maintenance access roads are required at the following locations:

- Communication hubs;
- Fiber Optic Terminal Cabinets (FTC);
- HAR Transmitters;

- Camera locations that are not adjacent to the roadway (see camera pole location requirements). In this case, the maintenance access road shall be built within 10 feet of the camera pole and shall be reachable by the bucket truck described in the camera pole section.

## **1.13 Work outside of the project limits**

### **1.13.1 Cabling**

Some projects may require a connection to the existing ITS infrastructure that is outside of the project limits. This is acceptable as long as there is an existing conduit path between the new and existing systems. As long as no soil is being disturbed, installation and termination of cables under these conditions are considered normal maintenance work and can be done outside of the project limits. Whenever working outside of the project limits, the designer should always communicate to the project office the type of work being performed.

### **1.13.2 Hardware**

Most projects that include installation of equipment in the field will require head-end equipment to be installed in a hub and/or at the traffic management center (TMC). This work is almost always performed outside of project limits. This is acceptable, as this type of work is considered normal maintenance and can be performed by the Contractor regardless of the project limits. Another solution, if approved by the NWR ITS Engineer, is to list the required hub and TMC equipment in the special provisions supplied to WSDOT. WSDOT would then receive the equipment from the contractor and perform the final installation of the equipment. Note that hub and TMC equipment are a crucial part of the design and without them, the field devices that they serve will not function.

### 1.14 Special designs

All new installations must be fully designed. In most cases, existing specifications and details have already been standardized and will be available for use. However, they may not work for every installation due to unique situations. If a unique installation is required, the designer will need to create specifications or details for the installation. Examples of this type of work are listed below:

- If a cabinet is designed with the installation of non-standard items, an elevation view of the cabinet showing the rack mounting units (RMU) being used is required. This allows reviewers to comment on the integrity of the installation, such as the fit and the ability to allow airflow through the cabinet.
- An elevation view of conduit installed on structures is required to show conduit routing. It does not need to show all expansion and deflection fittings since those are covered in the specifications. However, it does need to show all conduits bends and NEMA boxes. There is a maximum number of bends allowed between boxes and there are minimum bend radius requirements for conduits carrying fiber optic cables. These details must be provided as they are important for design review and verification of construction.
- Some installations require specialty items such as pole or bridge mounted cabinets, or cameras mounted to bridge structures. These items are not standardized and will require additional details to show how they are to be constructed.

Note that standard ITS installations are not always the right solution. Designers should always consider the purpose and the intended use of the device. For example, a standardized design may be based on the posted speed of a roadway. However, if the device is intended for use during peak period, it may be more effective to deviate from standardized designs and use the operating speed instead of the posted speed.

#### 1.14.1 Specifications and approval

- 1.14.1.1 All site-specific designs shall be accompanied by corresponding details and specifications that show all work required to be performed.
- 1.14.1.2 Some sites may require special designs, but all special designs require approval from the ITS Engineer.

## 2 CCTV

---

### 2.1 Overview

CCTV is used by the traffic management center (TMC) to visually monitor conditions on the highway network.

CCTV infrastructure provides time and cost savings during incident management by reducing the need to dispatch personnel to confirm every reported incident. For example, operators in the TMC can use CCTV feeds to determine whether an incident is severe enough to warrant emergency personnel response, allowing for prioritization.

CCTV can also be used to improve response times by confirming the location of an incident, which would otherwise be difficult due to the often imprecise reports from drivers. Operators can coordinate with emergency response personnel to determine the quickest way to access an incident.

Operations and maintenance activities also benefit from CCTV as they can be used to monitor equipment performance. CCTV is often used to determine the integrity of VMS displays, ramp metering operations, loop detection count accuracy and construction progress. For example, TMC operators visually confirm that ramp metering systems operating correctly and not causing excessive queuing onto local streets. Operators will also use CCTV to verify the readability of VMS displays, ensuring that there are no broken pixels within the text.

This document provides guidelines that regulate the performance requirements of Northwest Region CCTV systems.

## 2.2 CCTV Coverage

### 2.2.1 Coverage and spacing

In order to provide needed effectiveness, CCTV coverage needs to include the travelled lanes and shoulders of all roadways, including ramps. Ideally, nominal spacing between camera sites would be 0.5 miles, based on the optimal viewing distance of camera optics under ideal conditions. However, due to roadway geometry, roadside equipment, trees or structural obstructions, the distance may have to be reduced to provide the necessary coverage.

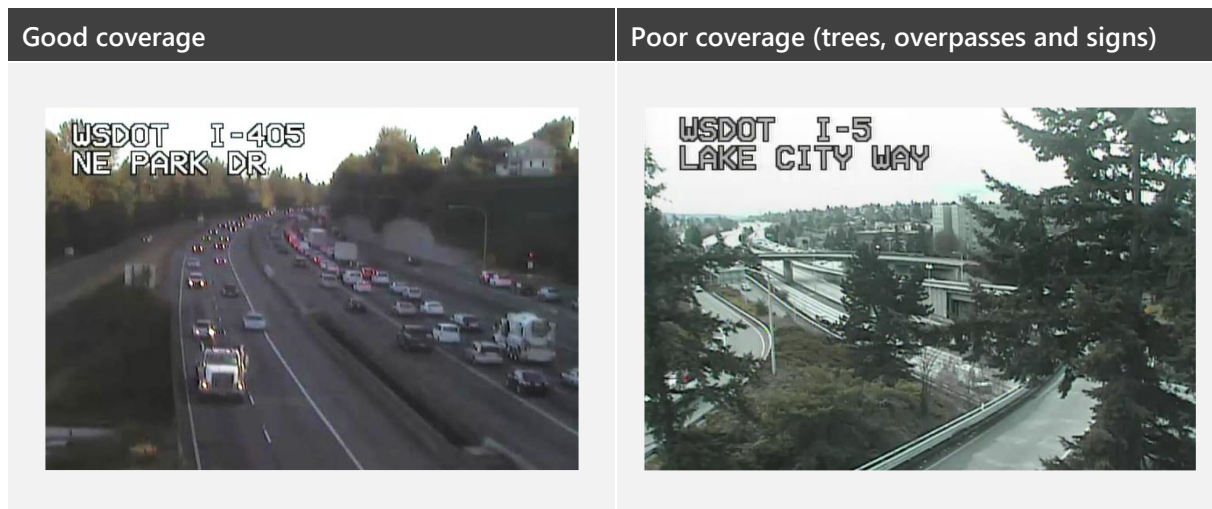

**Figure 2-1: CCTV coverage quality**

In locations of special interest, such as tunnels or sections of roadway with hard shoulder running, the nominal spacing should be reduced to provide greater redundancy to support additional operations, such as fire suppression systems or hard shoulder monitoring.

- 2.2.1.1 Cameras shall be located to provide 100% coverage of all travel lanes and shoulders. This is necessary for incident management.
- 2.2.1.2 Cameras shall provide an axonometric view of the roadway. A view along the plane of the roadway is not acceptable and is not considered as full coverage. The axonometric view is required to actively manage traffic, where operators must determine which lanes are impacted by an incident. This is important for incident management and reporting.
- 2.2.1.3 At interchanges, cameras shall provide 100% coverage of all ramps. The view should be optimized, if possible, for merging and weaving segments since there is a greater chance of collisions in these areas.
- 2.2.1.4 Maximum coverage shall be obtained using the least number of cameras possible. Additional assets result in higher maintenance costs for WSDOT.
- 2.2.1.5 No more than one camera shall be mounted on a single pole. If needed views cannot be attained from a single camera on a pole, another pole, possibly at a shorter height but in a different location, is required.

2.2.1.6 In a project area, existing cameras that no longer provide 100% coverage of all freeway lanes and ramps shall be removed. New cameras shall be placed where full coverage can be attained, or additional cameras shall be provided to provide 100% coverage.

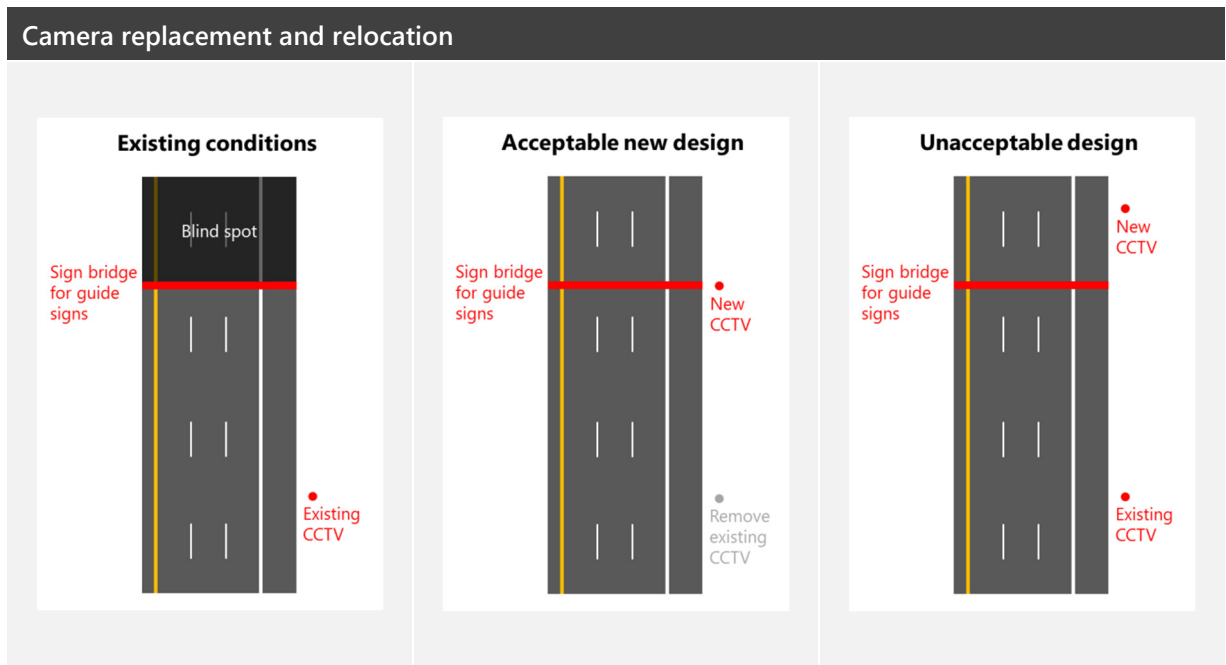
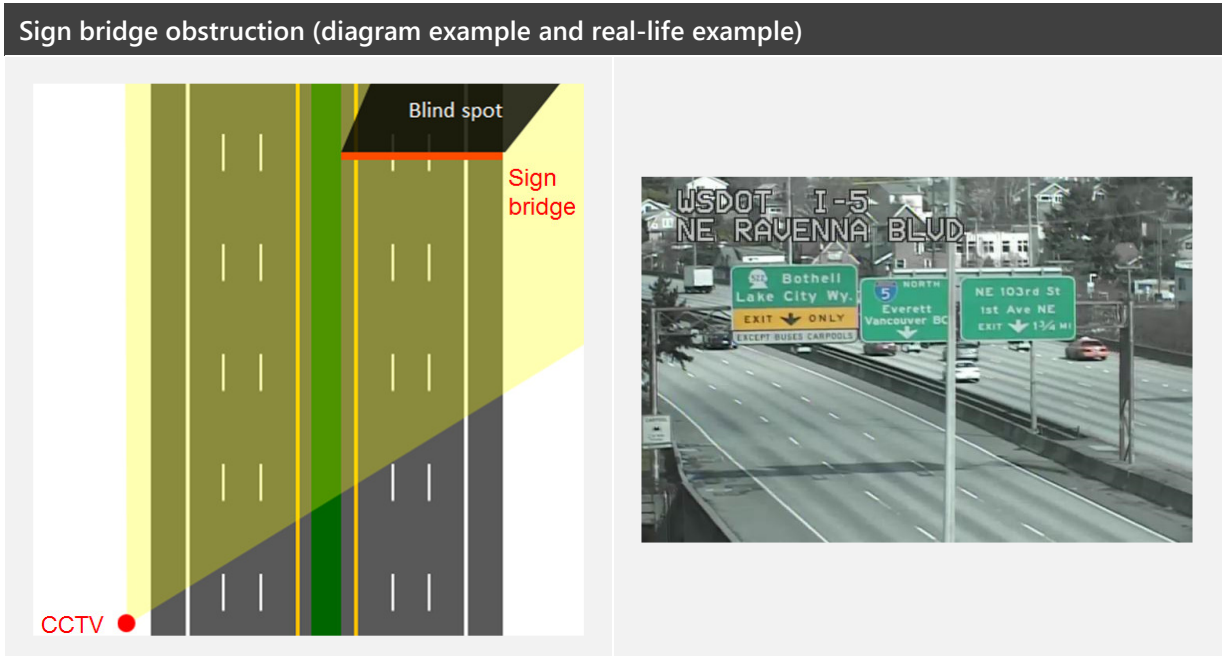

Figure 2-2: CCTV placement near guide signs

- 2.2.1.7 When determining sites for camera installation, the designer shall consider whether existing or future-planned traffic signs, gantries and bridges could obstruct the camera's coverage of the area.



**Figure 2-3: Sign bridge obstruction**

- 2.2.1.8 The designer shall consider roadway geometry (horizontal and vertical curves) when determining camera placement
- 2.2.1.9 The maximum longitudinal distance between consecutive cameras on a corridor is 4500 feet. This is an operational consideration that limits the distance that a camera can cover by itself to no more than 2250 feet in each direction. Even under normal weather, it is difficult to discern conditions at distances beyond 2250 feet.

## 2.2.2 Vegetation

CCTV coverage can be affected by the growth of vegetation along the roadway. This poses an operational challenge, since plant growth over time results in significant blind spots and reduces roadway coverage. The designer must consider the future growth of vegetation when choosing the location of the camera. This should be done by coordinating with the landscape architect to ensure that plant growth will not obstruct the camera view. This may be achieved by readjusting the location of the camera, adding additional cameras or by using low-growing plants.

### Poor coverage due to vegetation growth



**Figure 2-4: Poor coverage due to vegetation growth**

- 2.2.2.1 The designer shall consider whether future growth of vegetation may obstruct the camera's coverage of the area, especially when designing outside of summer months.
  - 2.2.2.2 Cameras shall be placed where vegetation growth will not interfere with camera views.
  - 2.2.2.3 Vegetation shall be selected to avoid interference with camera views.
  - 2.2.2.4 If it is impractical to relocate cameras or modify vegetation to achieve full coverage, additional cameras shall be installed to ensure full coverage.
- ### 2.2.3 Other viewing considerations
- In addition to the coverage considerations mentioned in the previous section, there are other factors that may influence the quality of CCTV coverage and its ability to meet operational requirements. Cameras are often located adjacent to other roadside equipment and under varying environmental conditions. Great consideration must be given to reduce any negative effects of the local surroundings that may impact the coverage quality.
- 2.2.3.1 Personnel shall be able to see the camera from its respective control cabinet. This is a maintenance consideration which allows the cabinet user to visually confirm the camera's performance without the need for additional personnel or equipment.
  - 2.2.3.2 For on-ramps with ramp meters, cameras shall provide the front view of at least one signal head per metered lane. The signal head indicators shall be visible without obstruction and under both daytime and nighttime lighting conditions. This is important for ramp metering operations since operators must verify that ramp meters are performing normally and safely.

- 2.2.3.3 Cameras shall provide the front view of HAR sign beacons and be capable of clearly seeing both beacons without obstruction and under both daytime and nighttime lighting conditions. This reduces maintenance dispatches and costs since operators can remotely verify equipment performance.
- 2.2.3.4 Cameras shall provide the front view of VMS, SMS, LCS, TRS, tunnel closure signs and signals, and be capable of clearly seeing the display pixels under daylight and nighttime conditions. This is required for operators to verify the messages or aspects being displayed. Operators will also use the cameras to visually confirm and accurately report problems to maintenance regarding failed pixels and modules.
- 2.2.3.5 For VMS, SMS, LCS and TRS displays, the designer must consider the LED cone of vision (i.e. viewing angles). The camera shall also be no more than 2000 feet upstream of the sign display, but no closer than the minimum distance required to clearly see the pixels under daylight conditions.

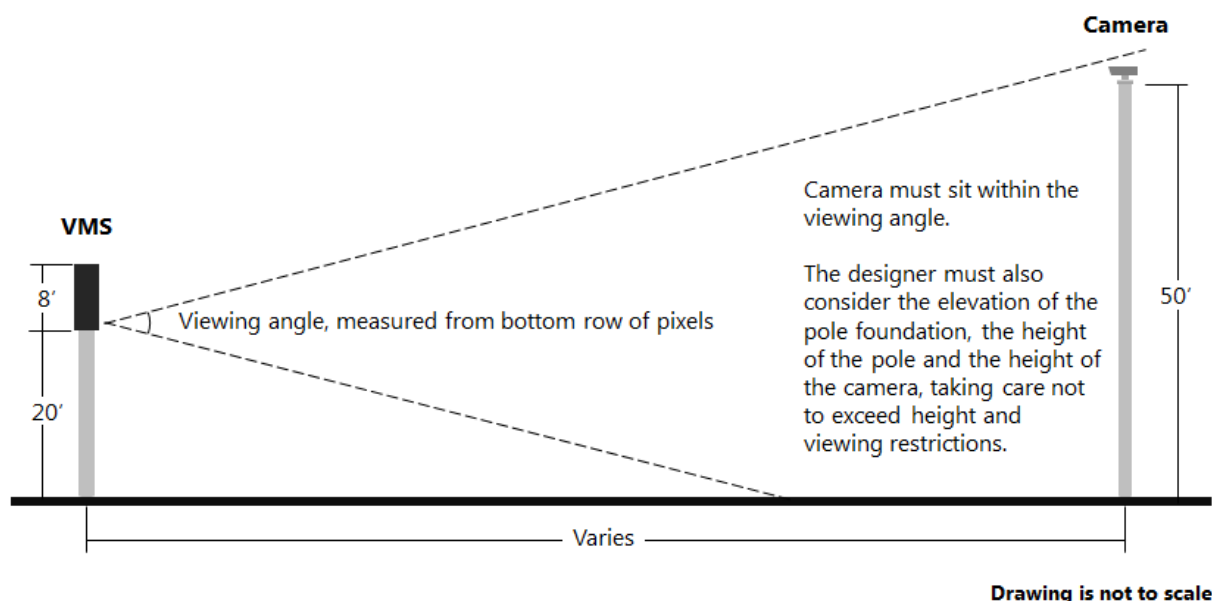

**Figure 2-5: CCTV camera must sit within the viewing angle**

- 2.2.3.6 For arterial locations, cameras shall provide a clear view of the intersection and the accompanying queuing at the intersection on all approaches.
- 2.2.3.7 At freeway interchanges, cameras shall provide a full view of ramps and signalized intersections.
- 2.2.3.8 Cameras shall be located so that the brightness of road lighting, including luminaire or tunnel lighting, will not close the camera's automatic iris and affect image quality.

- 2.2.3.9 Cameras providing coverage for short tunnels or lids shall be located at the downstream end directly at the physical openings of each tunnel. This is to prevent lighting conditions during the day from closing the camera's automatic iris and affecting image quality. Operationally, this allows operators to view what is happening at the tunnel entrance during all lighting conditions.



**Figure 2-6: Lighting effects on CCTV iris**

- 2.2.3.10 The designer shall consider the effects of locations that are susceptible to strong oscillations, such as on bridges or at locations with frequent gusting winds. Strong oscillations will render a camera unusable by operators. It will also damage hardware and reduce the camera's reliability, resulting in increased maintenance costs. Camera poles have been designed to be very rigid to minimize oscillations.
- 2.2.3.11 Cameras shall not be mounted on sign bridges, luminaire poles or other supports that are more vulnerable to oscillations than a camera pole.



**Figure 2-7: Vibration effects on CCTV image**

## 2.3 Infrastructure

### 2.3.1 Camera

2.3.1.1 Cameras shall be capable of pan, tilt and zoom (PTZ) functions.

2.3.1.2 Existing cameras and control cables within the project limits shall be replaced if any of the following conditions are met:

- If it is required by contract documents;
- If the existing camera is more than 10 years old before physical completion of the contract;
- If the camera model is not current with the Northwest Region ITS specifications. **Note:** Replacing existing cameras that transmit NTSC video and RS-422 data with IP cameras may cause significant impacts to the existing CCTV network. Such replacement may require additional cameras, poles and cabinets to satisfy viewing requirements due to the distance limitations of Ethernet communication.

2.3.1.3 If the camera is replaced, the camera control cable shall also be replaced.

### 2.3.2 Camera pole

2.3.2.1 For freeway applications, a camera shall not be mounted on anything other than a WSDOT-approved camera pole.

2.3.2.2 If the camera pole is located more than 100 feet from the cabinet, a junction box for a conduit containing the camera control cable shall be located at the base of the camera pole.

2.3.2.3 The camera pole shall not be located more than 10 feet from the edge of the pavement (maintenance pullout). Poles located further than 10 feet from the edge of the pavement shall be provided with a maintenance access road.

2.3.2.4 Camera poles shall be 50 feet tall unless approved by the NWR ITS Engineer. This is to maintain a standard pole height that is adequately tall to provide a good viewing angle above traffic.

2.3.2.5 Alternative camera pole heights between 10 and 65 feet can be considered by the designer if there are no other ways to achieve a necessary view, or if it is needed to reduce inventory in the field. It is desirable to avoid 65 foot poles when possible in the northwest region because there are a very limited number of trucks with a telescopic mast that will reach that height. Most bucket trucks in the northwest region are limited to a 52 foot vertical reach. All pole designs deviating from the standard 50-foot pole require approval from the NWR ITS Engineer.

2.3.2.6 The camera cable shall not exceed 300 feet. This is because current camera models stream video over an Ethernet cable, and current Ethernet cable standards allow for a maximum cable length of 100 meters (approximately 300 feet). Installations that require longer cables shall have approval from the NWR ITS Engineer. Additional equipment and an intermediate pole-mounted cabinet will be required for these locations if no suitable alternative can be found.

2.3.2.7 If a longer camera cable is approved, the distance between the camera cabinet and camera pole shall not exceed 600 feet under any condition.

2.3.2.8 For cameras mounted on or near bridges that cross the mainline, their supporting pole shall be mounted on the bridge or 10-15 feet away from the bridge. The 10 feet requirement is a maintenance consideration that allows enough room for side and underside access of the bridge with a UBIT (under bridge inspection truck).

2.3.2.9 Unless special approval has been granted by the WSDOT ITS Engineer, the camera mounted on the pole shall be reachable by a vehicle with a telescopic mast capable of extending 52 feet vertically and 36 feet horizontally (see **Figure 2-8: Vehicle with a telescopic mast**).

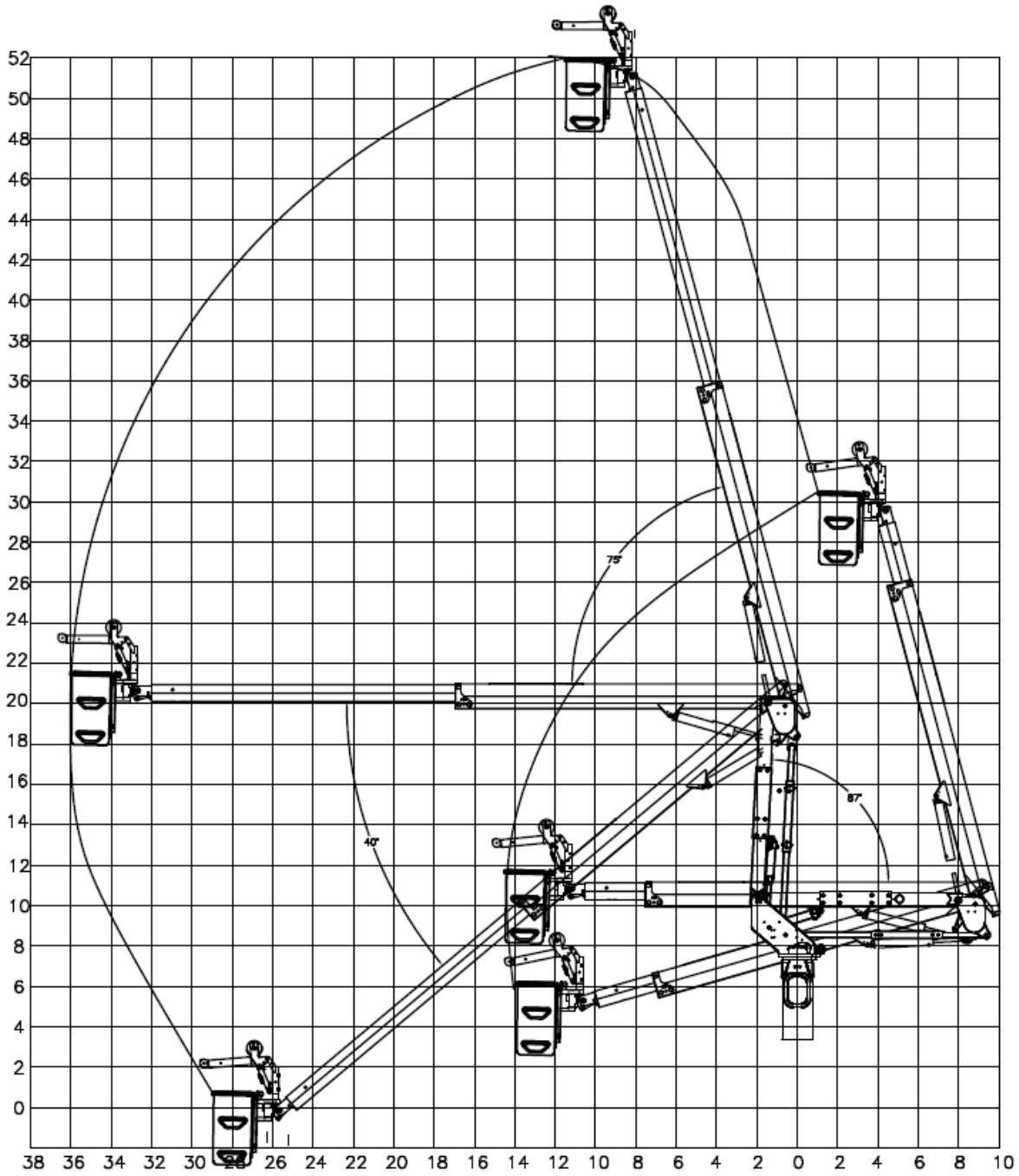

**Figure 2-8: Vehicle with a telescopic mast**

## 2.4 Camera cabinet

### 2.4.1 Placement

- 2.4.1.1 Camera cabinets shall be located on the outside shoulder (the right-hand side shoulder in the direction of travel of a roadway).
- 2.4.1.2 Camera cabinets shall be placed adjacent to the camera pole whenever possible.
- 2.4.1.3 Camera cabinets shall use the same foundation as other nearby cabinets when possible.
- 2.4.1.4 One camera cabinet may be used by multiple cameras on the same roadway, provided that the distance criteria between the camera and the cabinet are satisfied. A maximum of 4 cameras may be installed in a single cabinet, assuming all other design criteria are satisfied.

# 3 Loop detection

---

## 3.1 Overview

Loop detection is used to monitor traffic flow by measuring vehicle presence, allowing the roadway operator to derive speed, occupancy and volume data for traffic management and analysis purposes.

Many ITS devices and traffic management strategies, such as congestion monitoring, ramp metering, queue protection and HOT lanes, require loop detection. The associated performance assessments of these devices and strategies also require data collected from loop detectors.

Therefore, it is vital that loop detectors be designed with high reliability, generally a combination of maximum uptime, minimum time spent on maintenance and high-quality data collection.

This document provides guidance to achieve the desired characteristics of loop detection systems.

## 3.2 Coverage

### 3.2.1 Mainline

3.2.1.1 Between interchange mainline loops, mainline data stations shall be equally spaced at a distance not to exceed 0.5 mile (2640 feet). If there are conflicts or other criteria that needs to be satisfied that prevents this requirement from being met, the location of a single set of loops may be adjusted by up to 300 feet in either direction.

3.2.1.2 At all locations, 2-loop speed traps shall be installed in all mainline lanes, specialty use lanes and shoulders intended for hard-shoulder running facilities (for transit or otherwise) within the project limits.

3.2.1.3 Loops shall be installed in all on- and off-ramp lanes with the following requirements:

- Loops installed on off-ramps shall be located downstream of, and within 150 feet of, the physical separation of the roadway from the ramp, i.e. gore nose or just downstream of a barrier;
- Loops installed on non-metered on-ramps shall be upstream of, and within 150 feet of, the physical separation of the roadway from the ramp, i.e. gore nose;
- Loops shall be installed at the beginning and at the end of any ramp that connects one freeway to another freeway. The upstream loop shall be labelled as an off-ramp loop for the roadway that the ramp is separating from, and the downstream loop shall be labelled as an on-ramp loop for the roadway that the ramp is joining. These loops will generally be connected to different cabinets.
- Loops installed on all on- and off-ramps shall be wide loops (Type WR or R1W).

## 3.3 Placement considerations

### 3.3.1 Location for data reliability

Loop detector data quality is heavily influenced by the physical placement of the loop detector. Certain locations of the roadway may not yield data that is useful for traffic management or performance assessment purposes and, in some cases, may negatively affect the performance of ITS systems.

For example, if a set of loops are placed in an area with higher than normal weaving volumes, there will be a greater chance of “double-counting” as vehicles straddle the lane lines. As a result, a queue protection system relying on those loops may be given data inputs that overstate the severity of congestion in that area.

#### 3.3.1.1 Mainline loops shall not be located in the following areas:

- In locations where the roadway is tapering outwards to add a lane;
- In locations where a lane is being merged into the remaining lanes;
- In areas with a higher than normal rate of weaving and lane changes;
- In areas with high volumes of merging or diverging traffic.

3.3.1.2 Mainline loops shall be located downstream of and within 100 feet of the gore nose or physical separation of off-ramps.

3.3.1.3 Mainline loops shall be located upstream of and within 100 feet of the gore nose or physical separation of on-ramps.

### 3.3.2 Additional considerations for Active Traffic Management

3.3.2.1 Loop-based speed detection shall be provided between all ATM installations adhering to one of the following options:

- Option 1 (preferred): A single location of speed loop-based detection centered ( $\pm 300$  feet) between two ATM installations (greater than 1000 feet from either ATM installation).
- Option 2 (if option 1 is not possible): Two locations of speed loop-based detection between two ATM installations (both greater than 500 feet from their nearest ATM installation).

3.3.2.2 Where neither option 1 nor option 2 are attainable and where all other data station loop spacing requirements are satisfied, install a supplemental Wavetronix speed detector midway between ATM installations ( $\pm 300$  ft). This option does not replace the need for loop-based mainline detection.

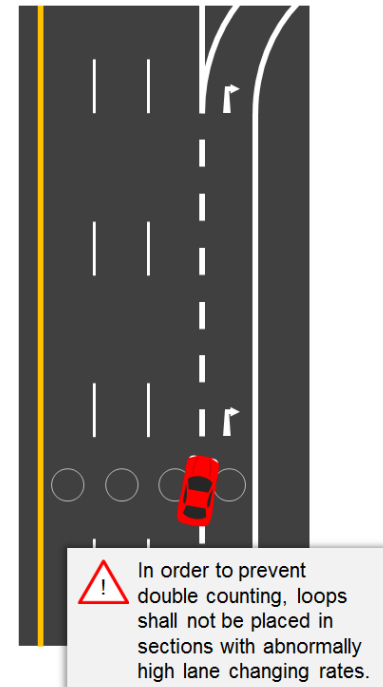

**Figure 3-1: Loop placement**

## 3.4 Loop naming

### 3.4.1 Naming scheme

Operators and maintenance personnel often need to identify specific loops for analysis or maintenance purposes. In order to reduce confusion and the need for memorization, loop naming must follow a specific and consistent order. This loop naming scheme was developed so that the loop name effectively describes to the user the loop's location in the roadway along with its purpose. The naming scheme is especially valuable as the number and types of loops in the system has grown rapidly in the past few years and will only continue to expand.

#### 3.4.1.1 Loop names shall be 7-characters and shall use the following scheme:

Character 1 Roadway Class	Character 2 Roadway Type	Character 3 Direction	Character 4 Lane Class	Character 5 Lane Type	Character 6 Device type	Character 7 Lane #
– (Gen. Purpose)	M (Mainline)	S (Southbound)	– (Shared; thru)	– (Mainline)	– (Not S, T, R)	1
A (Auxiliary)	C (Collector dist.)	N (Northbound)	R (Right Adv. Q or shoulder)	A (Adv. queue)	S (Speed loop)	2
M (Used for Meter Rate)	R (Reversible)	E (Eastbound)	L (Left Adv. Q or shoulder)	D (Demand)	T (Speed trap)	3
D (Duplicate)	A (Arterial)	W (Westbound)	H (HOV; HOT)	I (Inter. Queue)	R (Meter rate)	4
O (Off system)	X (Cross street)		B (Bus Only)	O (On-ramp)	C (Coupled speed)	5
T (Toll/tag reader)			Y (Bicycle Only)	P (Passage)		6
0-9 (Border Wait)			V (Metered HOV)	Q (Queue)		7
			W (Metered HOV on shoulder)	X (Exit)		8
			Z (HOV on shoulder)	M (Merge)		9

**Table 3-1: Loop naming scheme**

- 3.4.1.1.1 Character 1: "A" is used for loops on a State Highway other than what the cabinet is named for. "T" is used for loops associated with a tolling site (trigger loops). Numbers (0-9) are used where multiple loops in the same lane connect to a single cabinet for uses like mainline queue detection.
- 3.4.1.1.2 Character 2: "A" and "X" are used for loops at arterial intersections.
- 3.4.1.1.3 Character 4: For GP shoulder (hard shoulder running or PUSL) use "R" or "L" to describe which shoulder is used, when looking downstream. Use "B" if the lane, ramp or shoulder is signed for Bus or Transit use only.

- 3.4.1.1.4 Character 6: “T” and “R” are reserved for archived measured speed and metering rate –they are not intended to be used for actual loop names. “C” is reserved for naming the 9<sup>th</sup> and higher speed loop in a single cabinet.
- 3.4.1.1.5 Character 7: Lanes are numbered right to left when looking downstream. Ramps are numbered upstream, right to left followed by downstream, right to left. In the case of shoulders, they take on the number of the lane they are adjacent to.

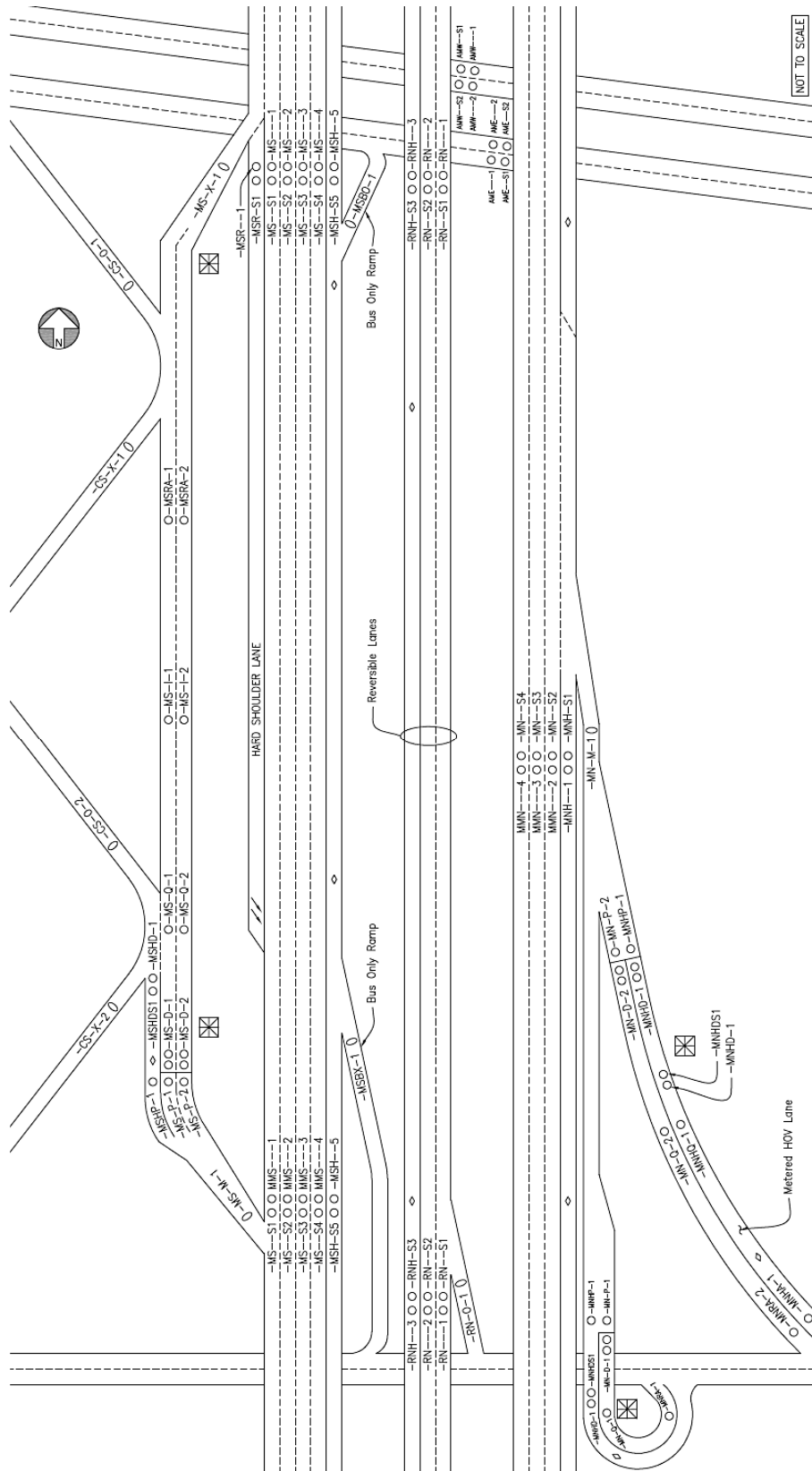

Figure 3-2: Loop naming scheme Installation

### 3.4.2 Maintenance and constructability requirements

The physical reliability of loop detection systems is dependent on the installation methods. Loop detection systems are easily impacted by external factors, such as loop location and pavement integrity. In the event that a loop detector does fail, it must be repaired quickly to minimize downtime, but with minimal impact to traffic flow.

On the other hand, data quality can be influenced by static or non-static interference to the loop detection zone, causing errors in traffic management equipment or performance assessments. As a result, great care must be given to minimize interferences to loop detection equipment in order to maintain high data quality.

- 3.4.2.1 In multilane configurations (mainline lanes, on-ramps and exit ramps), loop tails for loops in the same direction of travel shall be installed such that half ( $\pm 1$  lane) are routed to junction boxes on opposite shoulders of the same direction of travel. This is to avoid the need for full roadway closures when maintaining loop detection equipment.
- 3.4.2.2 Sawcuts for mainline loop tails shall not be cut across ramp lanes.
- 3.4.2.3 Sawcuts for mainline loop tails shall not be cut across lanes of a different direction of traffic.
- 3.4.2.4 Sawcuts for loop tails shall not exceed 50 feet.
- 3.4.2.5 Mainline loops for all lanes of a particular direction shall be aligned so they are directly adjacent to each other.
- 3.4.2.6 Loops shall be located in the center of their respective lane. Any loop whose edge is closer than 2 feet from the nearest lane line or edge stripe shall be recut in a location that is centered in the lane.
  - 3.4.2.6.1 In cement concrete pavement, loops shall be no less than 3 feet from transverse panel joints. This is to reduce the chance of loop damage from pavement deformation or failure, since concrete panels are weaker near the joints.
  - 3.4.2.6.2 In multilane locations where a wide round (WR) loop is used, the edge of the WR loop shall not be closer than 2 feet from the adjacent lane line; the far edge of the WR loop can be less than 2 feet from the edge stripe (refer to ITS loop details). The WR loop shall be recut if the edge of the loop is less than 2 feet from the adjacent lane line.
- 3.4.2.7 Loops more than 400 feet away from the cabinet shall have more than 4 turns (refer to ITS loop details).
- 3.4.2.8 Loop splices shall not be contained in a pull box or cable vault. These boxes often contain water due to their large size and depth. Loop splices shall be contained in a:
  - Standard junction box;
  - Barrier junction box;
  - NEMA junction box.

## 3.5 Cabinet

### 3.5.1 Location

Maintenance activities require both access to the contents of data station cabinets and visual confirmation of traffic conditions at the site of the vehicle detectors, often concurrently. Therefore, it is beneficial to place the cabinet so that the user facing the front of the cabinet will also be facing the location of the loops. This allows the user to visually observe field conditions while working with cabinet hardware, a configuration that will require just one maintenance person to perform basic maintenance duties rather than two (one for cabinet work and the other for visual confirmation).

3.5.1.1 Data station cabinets shall be located within 100 feet of the mainline loops, along the station.

## 3.6 Equipment

### 3.6.1 Lane width impacts

3.6.1.1 Wide loops (Type WR or R1W) shall be installed in all lanes wider than 12 feet. This is to improve detection of vehicles that may not be centered in the lane.

## 3.7 Loop termination

### 3.7.1 Loop termination schedule

3.7.1.1 The designer shall coordinate with the NWR ITS Engineer to create the correct loop termination schedule, as the loops must be connected to their cabinets in a specific order.

# 4 Ramp metering

---

## 4.1 Overview

Ramp meters use part-time signals to regulate the inflow of traffic from on-ramps onto the mainline by temporarily storing vehicles and then releasing them at a determined rate. The purpose is to prevent or delay traffic flow breakdown on the mainline by:

- Preventing or delaying the mainline from operating beyond stable conditions;
- Improving merge conditions by dispersing platoons of merging traffic.

The prevention or delay of traffic flow breakdown can lead to:

- Less congestion;
- Improved traffic flow on the mainline;
- Greater throughput during peak periods;
- Reduced travel time fluctuation (more reliable travel times);
- Reduction in primary and secondary collisions.

This document contains guidelines that will assist in the design of ramp metering and data collection systems. The design guidelines presented in the documents are intended to ensure that ramp metering systems and their related components meet the requirements necessary for consistent, effective and reliable operations.

## 4.2 Coverage

### 4.2.1 Coverage area

- 4.2.1.1 All on-ramps within the Seattle metropolitan area shall have a ramp meter installed for all lanes in accordance with the *WSDOT NWR Ramp Meter Design Policy Guidelines* document (attached).
- 4.2.1.2 On-ramps outside of the Seattle metropolitan area shall have a ramp meter installed when the sum of the volume in the right lane of the mainline and the volume of the on-ramp equals or exceeds 1700 vph during the peak hour in the year when operation begins.
- 4.2.1.3 Ramp meters shall be designed as a system. If a roadway has 3 on-ramps in close proximity with the upstream-most and downstream-most on-ramps qualifying for a ramp meter, the remaining on-ramp shall also be equipped with a ramp meter. This is to discourage diversions from metered ramps onto adjacent non-metered ramps.

## 4.3 Stop line location

### 4.3.1 Minimum stop line distance to merge

Acceleration distance and ramp meter storage capacity is determined by the placement of the stop line along the ramp. The *minimum* stop line distance to merge regulates the minimum length that must be provided for a vehicle to accelerate to highway speeds. Several factors can influence this minimum length, including the gradient of the ramp, the composition of on-ramp traffic and the traffic flow characteristics on the mainline.

4.3.1.1 The stop line distance to merge shall be as long as possible, without exceeding the maximum stop line to merge distance detailed in **section 4.3.2** and without compromising storage area on the ramp.

4.3.1.2 The designer shall consider gradients of the merge area.

4.3.1.3 The designer shall consider any speed characteristics of the ramp and mainline (e.g. 50 mph limits).

4.3.1.4 The designer shall consider flow breakdown characteristics.

4.3.1.5 The designer shall consider that:

- Uphill gradients reduce acceleration and require longer acceleration distances; and
- Downhill gradients aid acceleration and require shorter acceleration distances.

4.3.1.6 The designer shall consider the horizontal curvature of the ramp and determine whether increasing the stop line distance to merge will provide a benefit for drivers, since drivers may not use the extra distance for acceleration while traversing a sharp horizontal curve.

4.3.1.7 On loop ramps, the ramp meter shall be placed as close to the downstream end as possible. This is to maximize storage capacity and provide adequate sight distance to the ramp meter signal. Placing the ramp meter further back will reduce the sight distance due to the ramp curvature while providing little benefit for acceleration, as drivers are unlikely to use the extra distance for acceleration due to the tight horizontal curve of the ramp. See **Figure 4-1: RM location on ramps**.

4.3.1.8 A deviation from standards may be needed to reduce acceleration distance in order to increase storage, or additional metered lanes may need to be added.

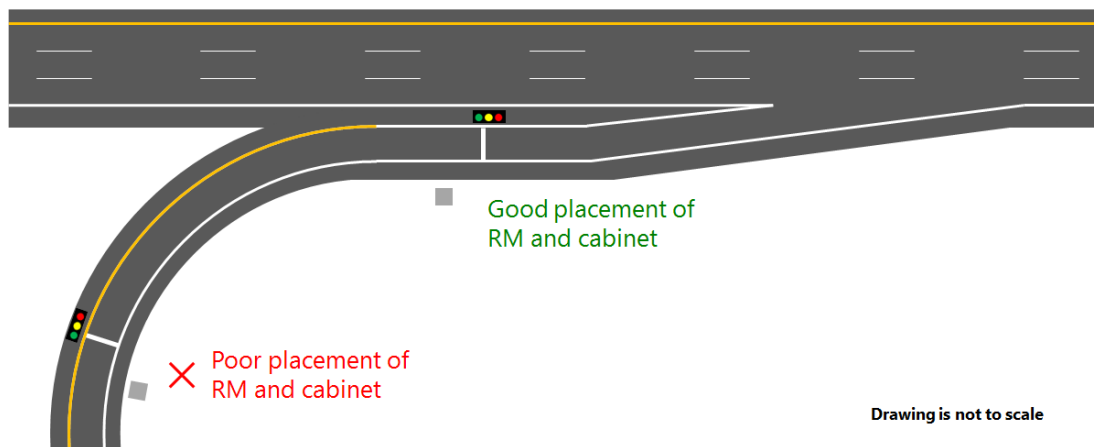

**Figure 4-1: RM location on ramps with sharp horizontal curves**

### 4.3.2 Maximum stop line distance to merge

Acceleration distance and ramp meter storage capacity is determined by the placement of the stop line along the ramp. The *maximum* stop line distance to merge regulates the maximum allowable length for acceleration. This is an important consideration for ramp metering, especially in the case of extremely long ramps.

Even if there is adequate space, it is not always beneficial to increase the acceleration distance to the maximum possible length. This is because a longer acceleration distance, combined with high release rates, may allow individual vehicles to catch up to the vehicle ahead of them upon leaving the ramp meter stop line, thus redeveloping into undesirably large platoons. This behavior reduces the effectiveness of ramp metering and should be minimized by carefully evaluating the maximum distance between the stop line and the merge.

This consideration becomes even more crucial when traffic composition for the on-ramp contains a high percentage of heavy vehicles.

- 4.3.2.1 Designers shall ensure that the acceleration distance from the stop line is short enough to prevent vehicles released at separate intervals from being able to regroup before merging.

### 4.3.3 Storage capacity

Storage for ramp meter operations needs to be sufficiently large to accommodate vehicles as they wait for the ramp meter. The storage capacity should be sufficient to prevent ramp meter queues from extending beyond the entrance of the ramp and into adjacent local roads, especially at signalized intersections and arterials where through traffic is impeded by ramp overflow. Storage overflow can impede traffic on the local arterial. It is a highly-politicized topic and can cause conflicts of interest between stakeholders.

The storage capacity is determined primarily by the location of the stop line and the upstream terminus of the ramp. In addition to typical factors such as heavy vehicle composition and roadway gradient, factors that must be considered for storage requirements include:

- Ramp demand: A high hourly flow will generally require larger storage areas in order to accommodate queued traffic;
- Distribution of ramp demand: If the upstream terminus of the ramp is served by a busy signalized intersection (e.g. arterial crossing) or a roundabout, there may be large platoons of vehicles entering the ramp storage at short intervals. In such cases, the ramp may quickly fill up, only to be insufficient to store the next platoon. In this situation, a larger storage area should be provided;
- Ramp metering algorithm: WSDOT uses a fuzzy-logic-based algorithm for ramp metering. The algorithm responds to real-time traffic conditions and adjusts rates to match demand. More congestion on the mainline will result in a lower ramp metering rate. On the other hand, more queuing on the on-ramp will result in a faster ramp metering rate. The algorithm will attempt to balance the two situations.

4.3.3.1 If traffic modeling is being performed for a project, storage for ramp meters shall be capable of accommodating forecasted demand for 20 years from the day when operation begins, assuming a ramp metering rate of 12 vehicles per minute per lane. Storage on any ramp shall not be less than 450 feet per lane.

4.3.3.2 HOV volume shall not be subtracted from the peak hour volume when calculating ramp storage.

4.3.3.3 If traffic modeling and forecasting are not being used, the designer shall use the following table to determine the minimum length of storage, which shall not be less than 450 feet.

Current peak hour volume	Metered Lanes		
	1	2	3
<b>1-300</b>	450 ft	-	-
<b>301-400</b>	525 ft	-	-
<b>401-500</b>	600 ft	-	-
<b>501-600</b>	700 ft	-	-
<b>601-900</b>	-	900 ft	-
<b>901-1000</b>	-	1050 ft	-
<b>1001-1100</b>	-	1200 ft	-
<b>1101-1200</b>	-	1400 ft	-
<b>1201-1600</b>	-	-	1350 ft
<b>1601-1700</b>	-	-	1575 ft
<b>1701-1800</b>	-	-	1800 ft
<b>1801-1900</b>	-	-	2050 ft
<b>1901-2000</b>	-	-	2300 ft
<b>2001-2100</b>	-	-	2550 ft
<b>2101-2200</b>	-	-	2800 ft
<b>2201-2300</b>	-	-	3050 ft
<b>2301-2400</b>	-	-	3300 ft
<b>2401-2500</b>	-	-	3550 ft
<b>2501-2600</b>	-	-	3800 ft
<b>2601-2700</b>	-	-	4000 ft

All storage values shown are a total for all lanes. The storage in each lane does not need to be divided equally; however, the storage of any lane on a multilane ramp shall be no less than 350 feet.

4.3.3.4 Modeling shall be used for ramps with volumes over 2,000 vph to confirm the necessary storage capacity.

#### 4.3.4 Number of metered lanes

It is often not feasible to increase storage capacity by lengthening the on-ramp. In such cases, storage capacity can be increased by adding lanes.

4.3.4.1 A minimum of 1 metered lane shall be provided when the current peak hour volume is less than or equal to 600 vehicles per hour.

4.3.4.2 A minimum of 2 metered lanes shall be provided when the current peak hour volume is between 601 and 1,200 vehicles per hour.

4.3.4.3 A minimum of 3 metered lanes shall be provided when the current peak hour volume is over 1,200 vehicles per hour.

4.3.4.4 Storage for all metered lanes shall extend as far up the ramp as possible, but at a minimum, all lanes shall extend at least 50 feet upstream of the queue loops.

4.3.4.5 All existing HOV bypasses shall be converted to metered lanes. The lane designation shall be converted to GP unless determined otherwise by the region Traffic Engineer.

4.3.4.6 No new HOV bypass lanes shall be constructed unless determined by the region Traffic Engineer. In that case, the HOV bypass lane shall adhere to the following:

- For ramps without existing HOV facilities (arterial HOV lane, bus stop, etc.), the HOV bypass lane shall be located to the left side of the metered lane(s) whenever possible;
- For ramps with existing HOV facilities (arterial HOV lane, bus stop, etc.), the HOV bypass lane shall be located on the same side as the existing HOV facility.

#### 4.3.5 Using the shoulder as storage

A metered shoulder should be constructed for all multi-lane ramp meters in lieu of a full-time metered lane whenever feasible. Reducing the number of full time lanes on a ramp reduces merge conflicts and excessive passing behavior. Use of the shoulder for a metered lane requires a full-depth hard shoulder. In this situation, the shoulder is used as a metered lane when the ramp meter is in operation. It remains a shoulder when the ramp meter is off. Minor widening may be needed to accommodate additional shy distance to the physical edge of the roadway for queuing traffic. In some cases, the physical edge of the roadway may also need extra shy distance to the barrier (refer to WSDOT Design Manual Chapter 1610).

## 4.4 Cabinets

### 4.4.1 Cabinet type

Ramp meters and data station equipment are standardized and designed to be mostly interchangeable. The resulting economies of scale simplify the system while reducing costs associated with procurement, manufacturing, installation and maintenance. For example, in the event that a ramp meter cabinet becomes inoperable, a data station cabinet can be used as a replacement within a very short turn-around time if no other spares are available.

4.4.1.1 Ramp meters and data stations shall use the same type of cabinet with the same contents.

### 4.4.2 Additional cabinet placement considerations for ramp metering

Maintenance activities require both access to the contents of ramp meter cabinets and visual confirmation of ramp meter operations, often concurrently. Therefore, it is beneficial to place the cabinet so that the signal heads are visible from the cabinet, a configuration that will require just one maintenance person to perform basic maintenance duties rather than two (one for cabinet work and the other for visual confirmation).

4.4.2.1 A ramp meter cabinet shall be located where the faces of the signal heads are visible from the cabinet.

4.4.2.2 A ramp meter cabinet shall be located so it is accessible from the ramp.

4.4.2.3 A ramp meter cabinet shall be provided for each physically-separated on-ramp being metered. Note that cabinets are capable of controlling a ramp with a maximum of 3 adjacent lanes. They are not capable of controlling 4 or more metered lanes.

## 4.5 Loop detection requirements

### 4.5.1 Installation

4.5.1.1 At a ramp meter, the maximum detector lead-in length for mainline loops and stop line loops (demand and passage) is 500 feet. The maximum detector lead-in length for all other loops is 800 feet.

4.5.1.2 Ramp meter cabinets shall contain all of the loops required for data stations as called for in **section 3** (mainline, ramp, exit, specialty use lane, etc.) as well as the specialized loops required for a ramp meter as identified in this section.

## 4.5.2 Coverage

4.5.2.1 The following loops shall be installed on all ramps (lanes and metered shoulders) equipped for ramp metering (see diagram on following page):

- Demand loop: Located as shown on the ITS details. The demand loop is used to detect the presence of a vehicle at the stop line waiting for a green indication.
- Passage loop: Located as shown on the ITS details. The passage loop is used to detect a vehicle crossing the stop line during the green indication.
- Queue loop: For ramps with less than 1000 feet of storage, the queue loop shall be located midway between the stop line and the advance queue loop (a minimum of 300 feet from the stop line). The primary use of the queue loop is to detect a short queue of vehicles and adjust the ramp metering rate accordingly.
- Intermediate queue loop: For ramps with 1000 feet of storage or more, the intermediate queue loop shall be located upstream of the queue loop and downstream of the advance queue loop.

For ramps with more than 1000 feet of storage, the queue and intermediate loops shall split the distance evenly between the demand loop and the advance queue loop, except where the distance between the demand loop and the queue loop would be less than 500 feet. In latter case, the queue loop shall be located at 500 feet and the intermediate queue loop shall be located midway between the queue loop and the advance queue loop.

- Advance queue loop: Located approximately 100 feet downstream from the entrance of the ramp (for this purpose, the ramp entrance is considered to be the location where a stopped vehicle on the ramp just encroaches into the cross-street). The advance queue loop is used to detect very long vehicle queues that are already (or in the process of) causing queue spillovers onto adjacent local streets. The maximum distance from the stop line shall be 1400 feet.
- Merge loop: Located 200 feet upstream from the painted gore point or at the end of the wide lane lines for a truncated gore. The merge loop is used to detect secondary queuing and may decrease the meter rate if necessary. Merge detectors shall use Type WR loops.
- Bus stop loop: Placed in an on-ramp bus stop to detect a stopped bus loading passengers. The bus stop loop is used to speed up the meter rate of the adjacent lane if necessary.

4.5.2.2 The following loops shall only be installed on ramps with HOV bypasses (HOV bypasses require region Traffic Engineer approval):

- HOV passage loop: Located in the HOV bypass lane. The HOV passage loop shall be aligned with the passage loop(s) across the ramp roadway, perpendicular to the direction of travel.
- HOV demand loop: Located in the HOV bypass lane, 300 feet upstream of the stop line of the adjacent metered lane.
- HOV demand speed loop: Located in the HOV bypass lane, 17 feet (center to center) downstream from the HOV demand loop.

### Typical ramp meter layout without HOV ramp metering

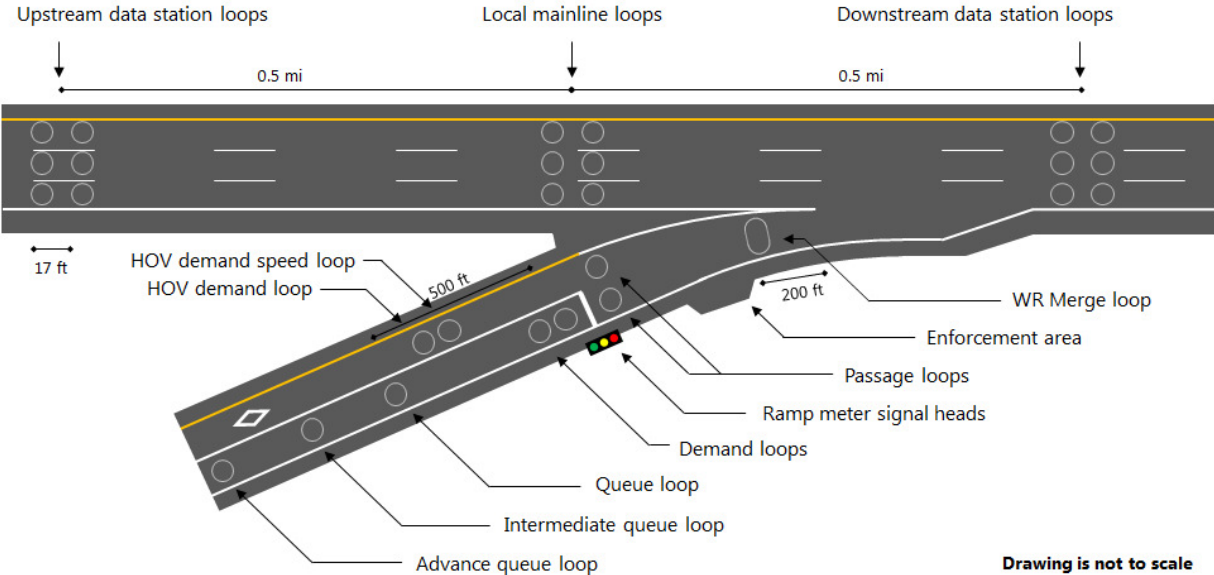

Figure 4-2: Typical ramp meter layout without HOV ramp metering

### Typical ramp meter layout with HOV ramp metering

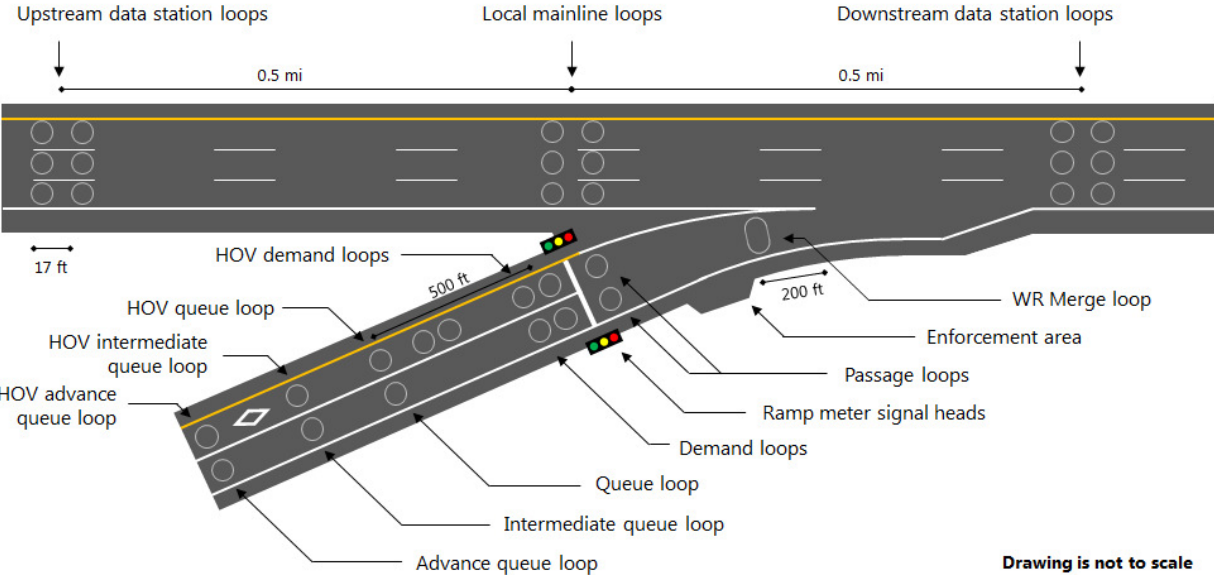

Figure 4-3: Typical ramp meter layout with HOV ramp metering

## 4.6 Ramp meter signal pole

### 4.6.1 Location

- 4.6.1.1 The stop line and ramp meter signal standards shall be installed on a tangent, or mostly tangent, section of roadway. The minimum length of the tangent section is 300 feet. This requirement may be omitted only if there are conflicts or other criteria that make it impossible to satisfy this requirement.
- 4.6.1.2 The ramp meter signal standard shall be visible to drivers as they approach the signal for a minimum of 300 feet.

### 4.6.2 Ramp Meter Signal Standard (Type 1 Ramp Meter Pole)

- 4.6.2.1 A Ramp Meter Signal Standard may only be used for single lane ramp meters.
- 4.6.2.2 A Ramp Meter Signal Standard shall be located no more than 8 feet from the edge stripe. If the pole must be further than 8 feet, an Overhead Ramp Meter Signal Standard shall be installed.
- 4.6.2.3 Ramp Meter Signal Standards placed closer than 5 feet from the edge stripe shall be behind or on top of a barrier.
- 4.6.2.4 The Ramp Meter Signal Standard shall be located adjacent to the lane that it is metering.
- 4.6.2.5 The Ramp Meter Signal Standard shall be located on the left side of the ramp whenever feasible and when there is no HOV bypass on the left.
- 4.6.2.6 The Ramp Meter Signal Standard shall include signing in accordance with the Standard Plans and the detail in **Figure 4-4: On-ramp with Type 1 Ramp Meter Pole** and **Figure 4-6: Signing for ramp meters**.

### 4.6.3 Overhead Ramp Meter Signal Standard (Type 2 Ramp Meter Pole)

- 4.6.3.1 An Overhead Ramp Meter Signal Standard may be used for ramp meters with 1 lane and shall be used for all ramp meters with 2 or more lanes.
- 4.6.3.2 Where used, an Overhead Ramp Meter Signal Standard shall be located 75 feet downstream of the stop line.
- 4.6.3.3 Any signal display mounted on an Overhead Ramp Meter Signal Standard shall be located within 1 foot of the center of its respective lane.
- 4.6.3.4 When an HOV bypass is approved by the region Traffic Engineer, an Overhead Ramp Meter Signal Standard shall not be located on the side of the ramp with the HOV bypass lane resulting in the HOV bypass lane being completely spanned by the mast arm. However, the mast arm shall be designed with a mounting bracket for a future signal display over the center of the HOV bypass lane.
- 4.6.3.5 Any installed Overhead Ramp Meter Signal Standards shall include signing in accordance with the Standard Plans and the detail in **Figure 4-5: On-ramp with Type 2 Ramp Meter Pole** and **Figure 4-6: Signing for ramp meters**.

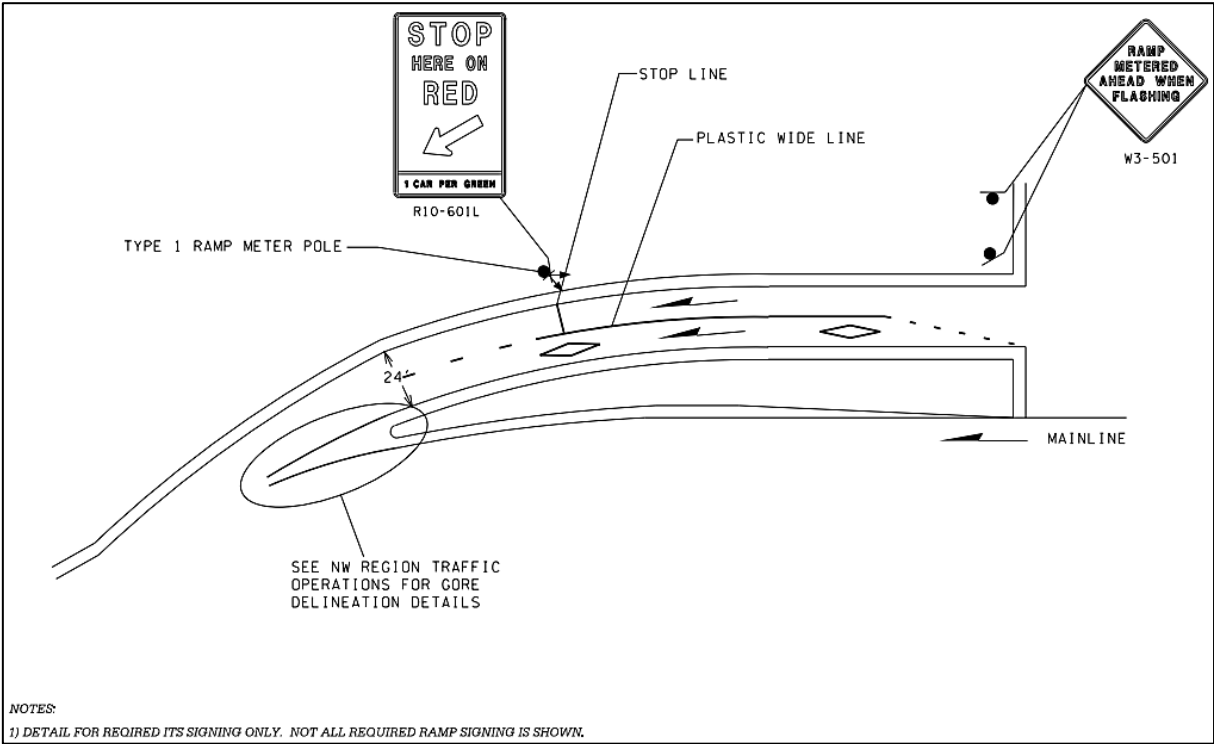

Figure 4-4: On-ramp with Type 1 Ramp Meter Pole

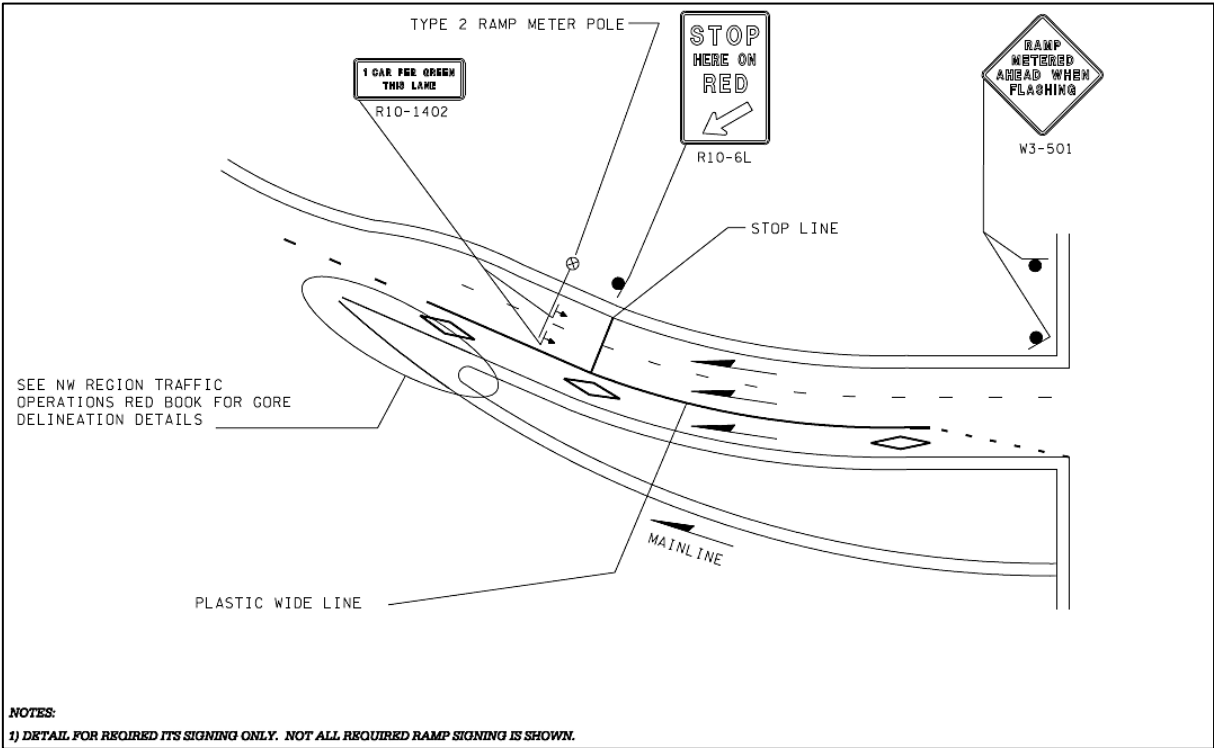
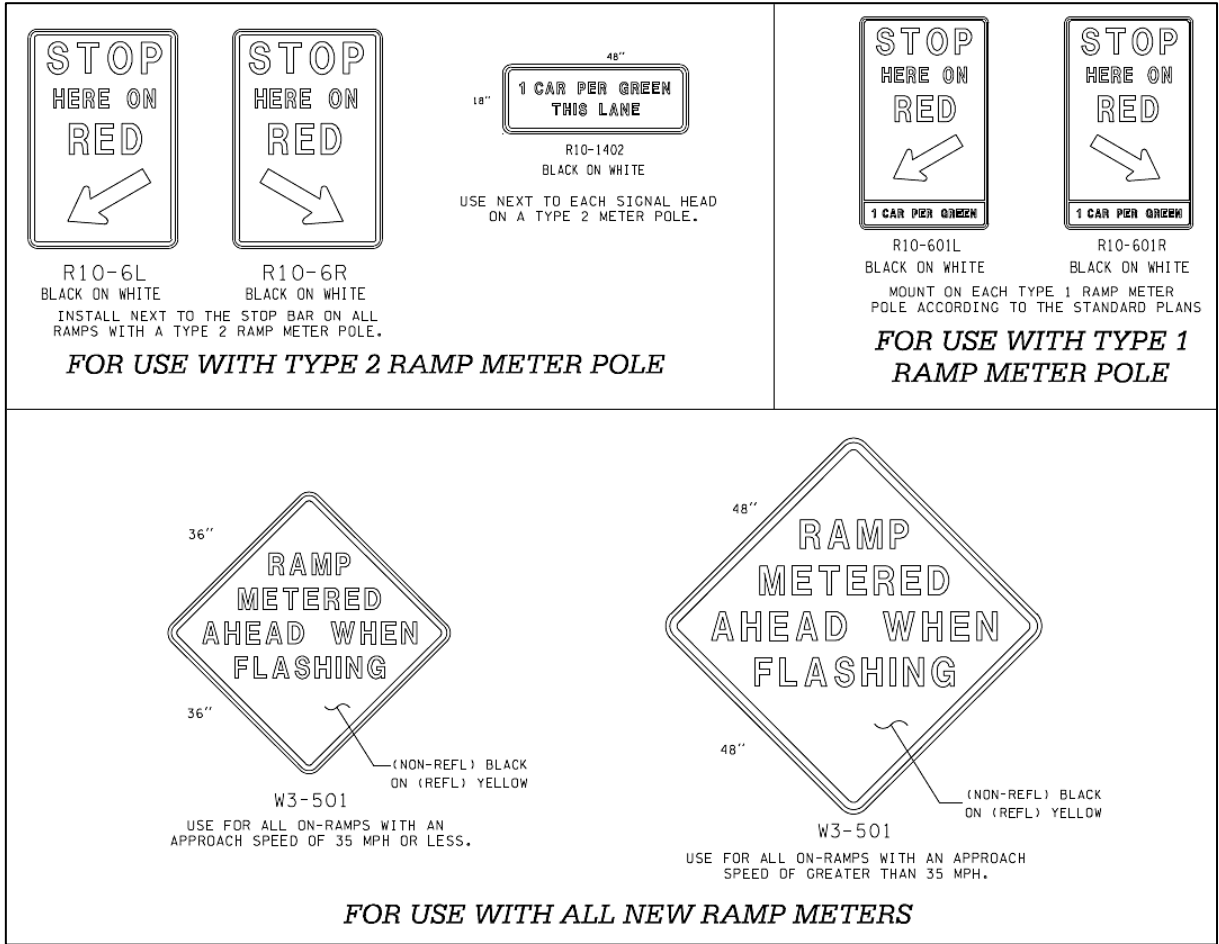

Figure 4-5: On-ramp with Type 2 Ramp Meter Pole



**Figure 4-6: Signing for ramp meters**

## 4.7 Advance Warning Sign and Beacon (AWS)

### 4.7.1 Placement

Advance warning signs and beacons (AWS) are used to notify drivers about ramp meter operations. There are several benefits for doing so. Operationally, AWS can deter drivers from using the ramp altogether, especially drivers who intend on using the highway for short-distance trips. AWS can also encourage drivers to take alternate routes. However, in order to act as a deterrent, the AWS must be visible before drivers commit to entering the ramp.

- 4.7.1.1 Each approach shall contain a clear view of an AWS before drivers commit to entering the ramp unless doing so would result in multiple beacons (e.g., AWS, RRFB, crosswalk beacon, etc) competing for a driver's attention. In order to separate decisions by drivers and reduce visual clutter, an AWS may need to be moved downstream of the entrance to the on-ramp. It is important to consider the priority of various beacons when determining their placement. When an AWS must be placed on the on-ramp, it should be visible as far upstream toward the ramp entrance as practical. It may be necessary to provide multiple AWS so that each approach has a clear view of at least one.
- 4.7.1.2 A mid-ramp AWS shall be provided on ramps longer than 1500 feet. The mid-ramp AWS shall be located 700 to 1100 feet upstream of the stop line.
- 4.7.1.3 For multilane facilities that serve multiple destinations (such as collector-distributor facilities), an overhead advance warning sign shall be provided on a sign structure over the lanes to be metered. The sign shall be located 1000 to 1500 feet upstream of the ramp meter stop line.

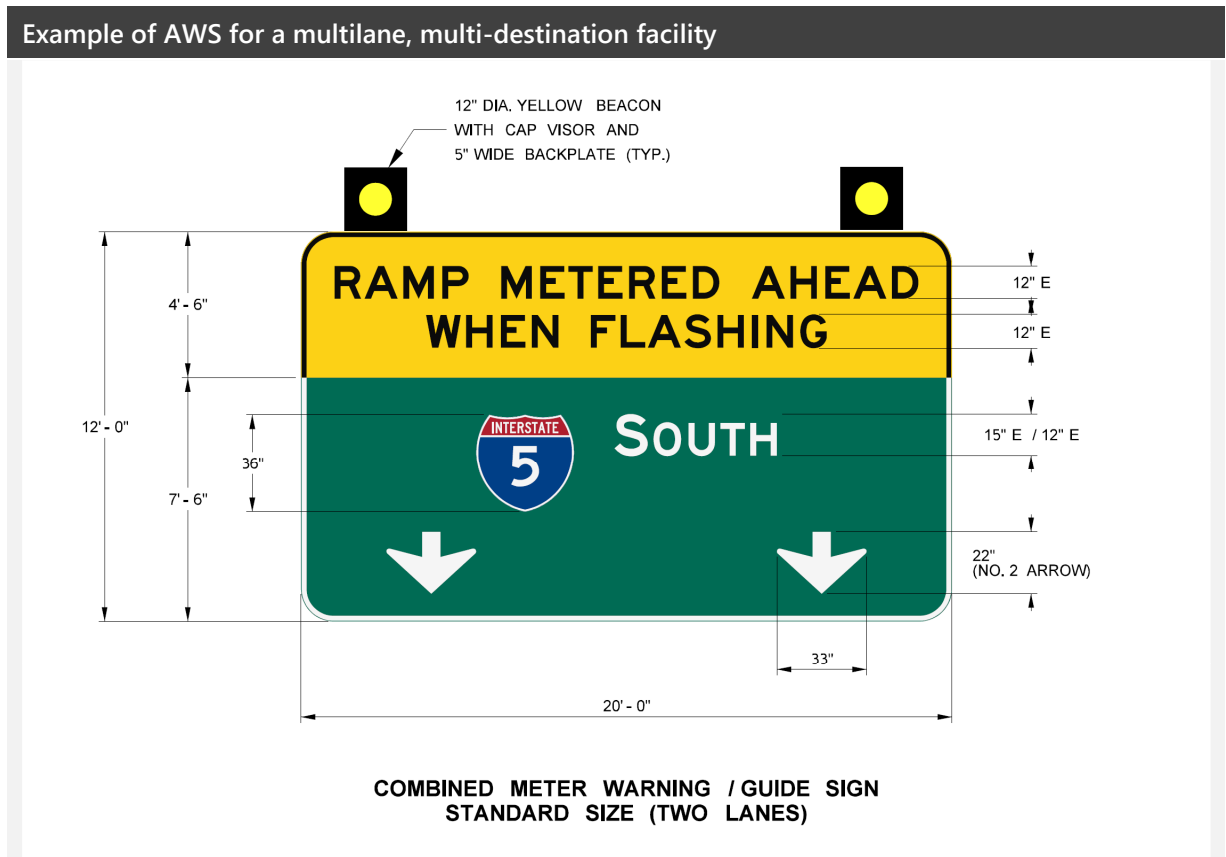

Figure 4-7: AWS for multilane, multi-destination facility

## 4.7.2 Sign details

- 4.7.2.1 All advance warning signs shall have black text on a yellow background.
- 4.7.2.2 A 3' x 3' sign shall be used for ramps with a signed approach speed less than or equal to 35 mph.
- 4.7.2.3 A 4' x 4' sign shall be used for ramps with a signed approach speed greater than 35 mph.
- 4.7.2.4 An AWS for a multilane, multi-destination facility shall be a special design meeting the NWR sign design requirements for text size and sign size. The AWS shall contain a green guide strip at the bottom with the highway shield and direction. The AWS shall contain two alternately flashing 12" yellow beacons with black backplates above the yellow portion of the sign. See **Fig 4-7, AWS for multilane, multi-destination facility** for an example of this type of sign.
- 4.7.2.5 The AWS shall be designed and constructed in accordance with the Standard Plans except that 3-conductor cabling shall be used in lieu of 2-conductor cabling.

## 4.8 Other requirements

### 4.8.1 Emergency vehicles

- 4.8.1.1 Ramps shall include preemption for emergency vehicles where all lanes are metered and where a shoulder at least 10 feet wide is not present, or is metered. The preemption sensor shall be placed either on the upstream terminus of the metered shoulder or on the signal mast arm for overhead mast arms.

# 5 Variable Message Signs

---

## 5.1 Overview

Variable message signs (VMS) are traffic control devices designed to display a variety of messages viewable by passing drivers. VMS allow operators in the Traffic Management Center to communicate with drivers quickly, reliably and effectively. They assist in TMC operations and aid in incident management, congestion management and operational efficiency.

VMS displays provide regulatory, warning and guidance information related to traffic control. The content of a VMS display should assist drivers in making decisions. Operational, road condition and driver safety messages are also acceptable messages.

Examples of VMS messages include collision information, delay information, travel times, advance roadwork notification and dynamic rerouting guidance.

In order for VMS infrastructure to maintain their operational effectiveness and reliability, many factors have to be considered in the design process, including spacing of the signs and maintainability. This document provides the design requirements for effective VMS infrastructure.

## 5.2 Standalone variable message sign

### 5.2.1 Location

Variable Message Signs (VMS) are most effective when they are used with relevance to time and location. In other words, the information being displayed must be geographically relevant and be applicable within a short amount of time after it is seen.

For example, a VMS 2-3 miles from an incident scene can provide useful information to drivers, such as lane closure information, as the time between visual recognition of the VMS message and the incident scene is very short. In contrast, information provided on a VMS 10 miles from an incident scene may become outdated once the driver has reached the incident scene. It is also likely that the driver may not retain the information provided by the VMS.

As a result, it is good practice to locate variable message signs at set intervals along a freeway corridor. This will allow operators to choose the most contextually relevant VMS and improve the effectiveness of the information being displayed.

Another consideration is the importance of VMS infrastructure during strategic diversion of traffic flow. Strategic diversions are used to reroute traffic onto alternate routes in the event that the primary route is unsuitable for use. Clarity of routing guidance can be improved by allowing drivers to read the diversion message twice before reaching the decision point.

An example application of a strategic diversion is shown below for traffic between Seattle and Redmond.

In all cases, variable message signs must be placed in areas that allow for adequate reading time. At 60 mph, a tangent sight distance of 800 provides about 9 seconds of reading time.

## Example VMS deployment

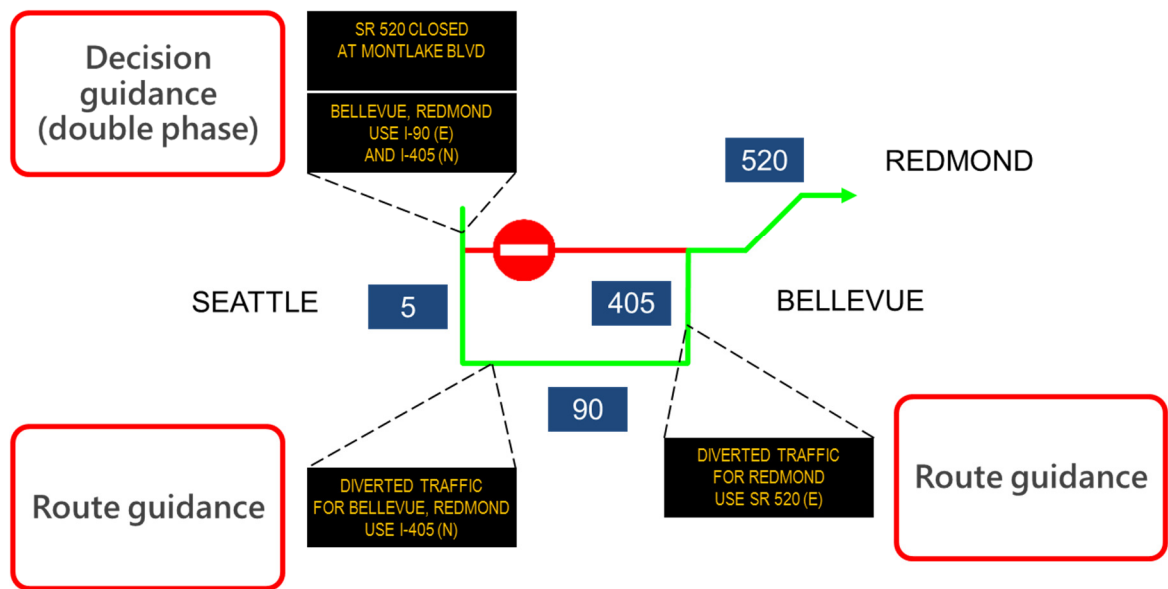
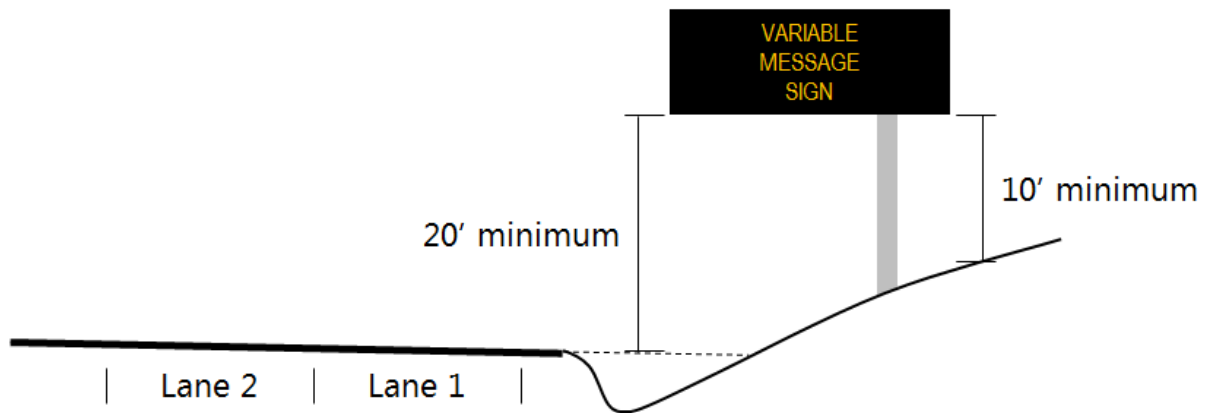

**Figure 5-1: Example VMS deployment for strategic diversions**

- 5.2.1.1 A VMS shall be provided every 3-4 miles along a corridor.
- 5.2.1.2 A VMS shall be provided upstream of a major decision point (e.g. freeway to freeway interchanges, any interchange with access to an alternate route, etc.). The VMS shall allow enough time for drivers to safely navigate to the exit of the interchange from the far lane. When determining the distance from the interchange, it should be assumed that drivers will not make the decision to exit until they have reached the location of the sign.
- 5.2.1.3 The location shall provide a minimum tangent sight distance of 800 feet. This is to provide adequate time for drivers to read the VMS display.
- 5.2.1.4 Locations with a high percentage of weaving, or adjacent to on-ramps or exit ramps, should be avoided whenever possible. Driver attention to the messages on a VMS is reduced when they are actively changing lanes or merging onto the highway.

## 5.2.2 Mounting

- 5.2.2.1 A VMS shall be centered over the directional roadway for roadways with 3 or more lanes in the same direction of travel.
- 5.2.2.2 A VMS may be shoulder-mounted on a "T structure" for directional roadways with 2 or fewer lanes in the same direction of travel.
- 5.2.2.3 The bottom of any part of the VMS housing over the roadway, including lanes and paved shoulders, shall be a minimum of 20 feet and a maximum of 25 feet above the roadway.
- 5.2.2.4 If the VMS is mounted above the unpaved shoulder, the bottom of the VMS housing shall be a minimum of 20 feet above a roadway profile line projected from the road surface and a minimum of 10 feet above the highest immediate ground surface.



**Figure 5-2: VMS over unpaved shoulder**

- 5.2.2.5 Maintenance walkways (catwalk) are required in accordance with the standard plans. The 5-ft catwalk noted in the Standard Plans as optional is required for all walk-in VMS installations.
- 5.2.2.6 The maintenance walkway shall extend to the fog line on the side of the road with the maintenance pullout.
- 5.2.3 **Cabinet**
- 5.2.3.1 The VMS shall utilize a ground-mounted 331-style cabinet.
- 5.2.3.2 The sign controller shall be located in the ground-mounted cabinet.
- 5.2.3.3 The cabinet shall be located on the same side of the road as the maintenance pullout.
- 5.2.3.4 The cabinet shall be located between 100 and 300 feet upstream of the VMS structure.

#### **5.2.4 Standalone VMS specification**

- 5.2.4.1 The VMS legend shall be full-matrix, full-color LED, capable of displaying 3 lines of text.
- 5.2.4.2 The character set shall be capable of displaying characters from 20 (hex) to 7E (hex), inclusive, of the ASCII character set.
- 5.2.4.3 Each line shall contain at least 18 characters.
- 5.2.4.4 For freeway applications, the character height shall be 18 inches.
- 5.2.4.5 For arterial applications, the character height shall be 12 inches.
- 5.2.4.6 For installations utilizing fiber optic cable between the controller cabinet and the sign, a minimum of 6-strand cable shall be used, with all strands terminated with connectors in patch panels in both the controller cabinet and in the sign housing.

## 5.3 Active Traffic Management sites

### 5.3.1 Installation location

Active traffic management (ATM) systems are used to support traffic control techniques such as queue protection and speed harmonization. ATM equipment is often mounted on sign bridges, but can also be supported by bridge structures or other appropriate structures along the roadway. In the following sections, an ATM site is designated as an “ATM installation” or an “ATM site”, regardless of the type of support being used.

Similar to variable message signs, active traffic management installations must be placed at set intervals to maintain contextual relevance. However, ATM signs provide traffic control information typically beginning only a mile upstream of an incident. Due to the tactical requirements of ATM systems, the installation intervals must be even shorter (nominally 0.5 miles) than those of VMS sites to provide necessary information in a timely manner.

The shorter spacing between ATM sites allows for better continuity of information as the driver passes from one site to another. Although inter-visibility of ATM installations is ideal for lane-control purposes, it is not practical in many areas due to signage crowding and roadway geometry.

However, it is necessary that lane-specific signs, i.e. lane control signs, appear to the driver to be in the correct lane when navigating roadway curves. This requirement is regulated by the minimum time that the sign must appear, from the driver’s perspective, in the correct lane along a horizontal curve. Failure to adhere to this requirement may lead drivers to incorrectly interpret lane-control information.

At interchanges, ATM can provide junction warning/control capabilities, where drivers are directed out of the right lane to provide more room for merging traffic. However, this is only possible if the installation is located upstream of an on-ramp.

- 5.3.1.1 Installations shall have 0.5 mile nominal spacing; however more frequent spacing may be necessary to accommodate densely spaced urban interchanges.
- 5.3.1.2 Installations shall not be located anywhere within a horizontal curve where the LCS appears, from the driver’s perspective, to be in the correct lane for less than 6 seconds at the posted speed. This is to prevent drivers from misidentifying the lane control sign that corresponds to their lane as they navigate the curve. See **Figure 5-3: Sight distance requirements for lane control signs.**

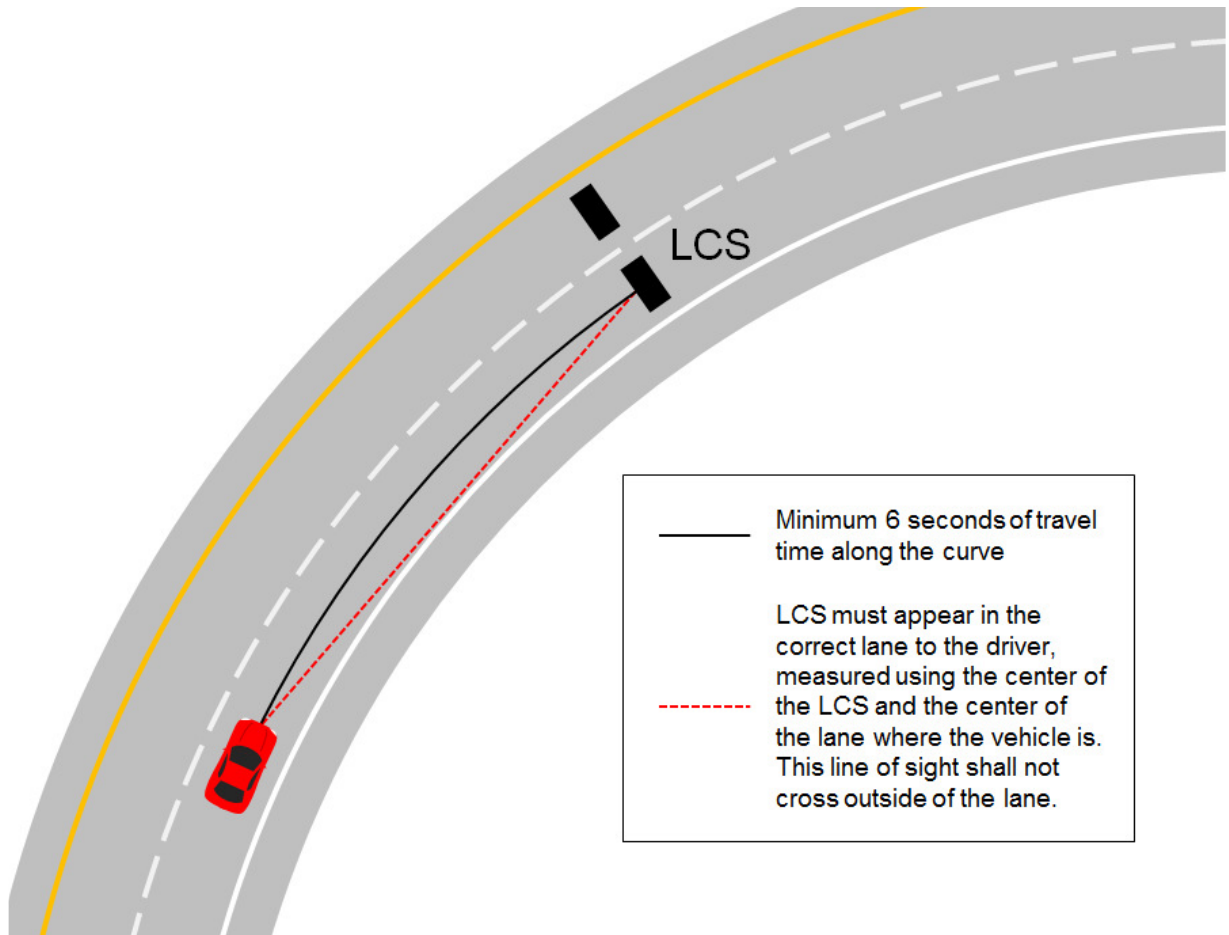

**Figure 5-3: Sight distance requirements for lane control signs**

- 5.3.1.3 Installations shall be a minimum of 800 feet upstream of an exit ramp.
- 5.3.1.4 Installations shall not be located within 300 feet of an on-ramp merge area, defined as the area between the tip of the gore point and the end of the merge taper.
- 5.3.1.5 Installations are allowed downstream of an exit ramp as long as other restrictions are met.

5.3.2 Lane control signs (LCS)

Lane control signs are used to communicate lane-specific traffic control information. Each lane is provided with its own LCS. These signs are used to display the following:

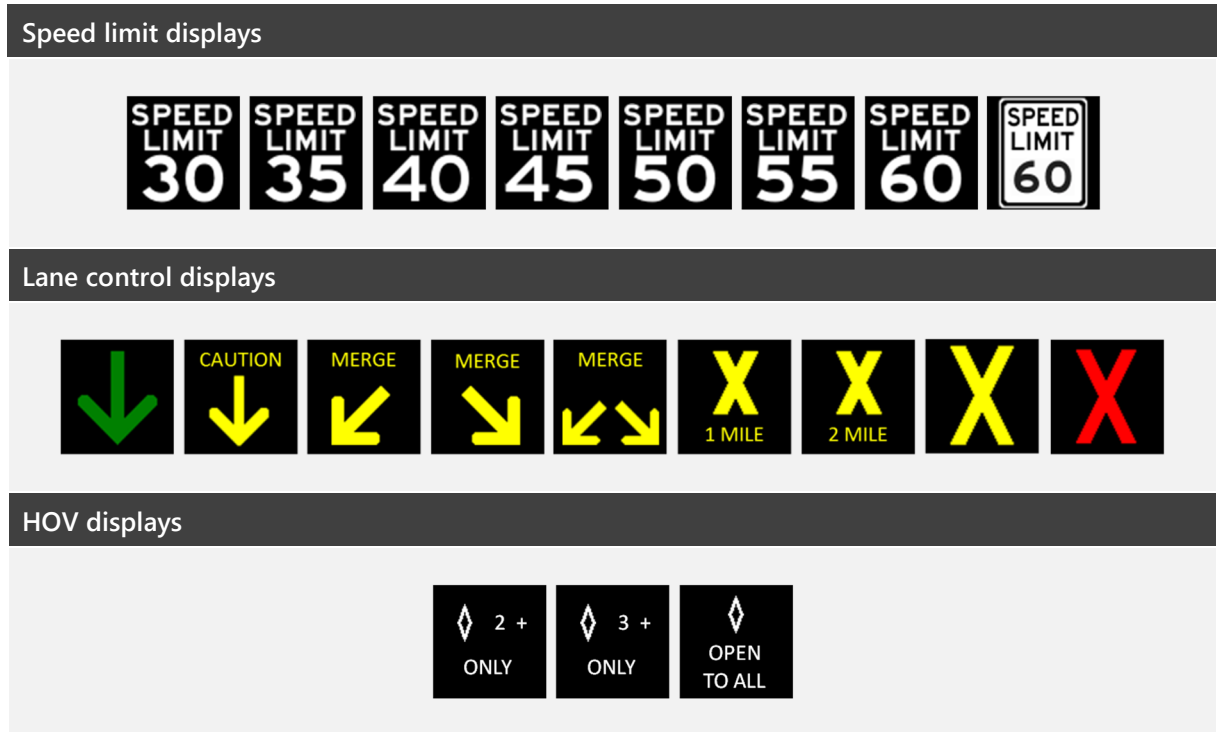

Figure 5-4: LCS displays

5.3.2.1 One LCS shall be centered over each mainline lane.

5.3.3 Lane control sign specification

5.3.3.1 The LCS display shall be full-matrix, full-color LED.

5.3.3.2 The LCS display shall have a viewable area of 5'x5', be high resolution and capable of displaying all messages shown above.

5.3.3.3 The LCS display shall be capable of displaying at least 6, 12-inch tall characters per line.

5.3.3.4 The LCS display shall be capable of displaying 2 lines of 9-inch tall characters with 1 line of 18-inch characters, or 4 lines of 9-inch tall characters.

### 5.3.4 Side-mounted signs (SMS)

Side-mounted signs provide supplementary information when LCS messages are deployed. They show messages that would otherwise be displayed on a full-size VMS, such as "Slow Traffic Ahead" and "Reduced Speed Zone". When no messages are deployed on the LCSs, the default speed limit is shown on SMS.

- 5.3.4.1 SMS shall be on every other ATM installation, alternating with VMS. Installations containing a VMS shall not contain an SMS.
- 5.3.4.2 SMS shall be installed in the median and on the right-hand side shoulder.
- 5.3.4.3 The horizontal distance between an SMS and the nearest mainline edge stripe shall be no more than 20 feet.
- 5.3.4.4 The top of each SMS should be mounted at the same elevation as the bottom of the LCS at the same ATM installation.
- 5.3.4.5 An additional SMS shall be provided when an ATM installation is upstream of an on-ramp, as shown by **Figure 5-5: Additional SMS for on-ramp**. The extra sign is needed to provide speed and incident information to ramp traffic that would otherwise not see the information displayed on the ATM installation.

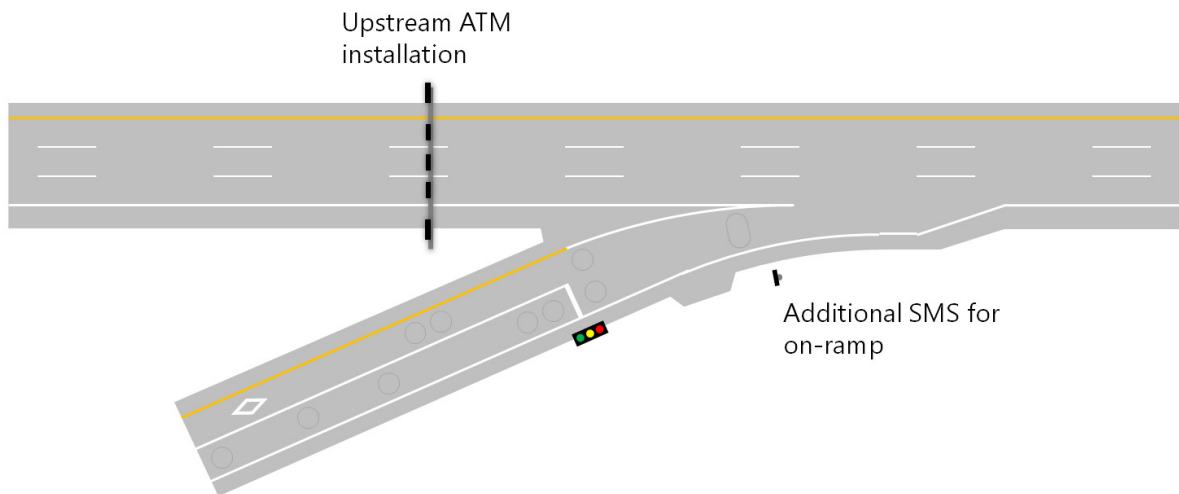

**Figure 5-5: Additional SMS for on-ramp**

### 5.3.5 Side-mounted sign specification

- 5.3.5.1 The SMS display shall be full-matrix, full-color LED.
- 5.3.5.2 The SMS display shall have a viewable area of 6'x6', be high resolution and capable of displaying 4 lines of text with 8 characters on each line.
- 5.3.5.3 The SMS display shall be capable of displaying at least 8, 12-inch tall characters per line.
- 5.3.5.4 The SMS display shall be capable of displaying 4 lines of 12-inch tall characters.

### 5.3.6 ATM Variable Message Signs (VMS)

ATM installations often contain a VMS to provide additional information to drivers. They are used for supplementary messages such as those regarding incidents, congestion and roadwork. Example messages include "Slow Traffic Ahead" and "RIGHT LANE CLOSED". Normally, a full-size VMS is used in an ATM installation. However, a smaller VMS may be used if the full-size VMS is not feasible.

- 5.3.6.1 VMS shall be provided on the first (most upstream) ATM installation of a corridor.
- 5.3.6.2 A small VMS shall not be installed unless a full-size VMS cannot be accommodated.
- 5.3.6.3 A VMS shall be provided at installations where the distance to the nearest upstream ATM site is more than 2 miles.
- 5.3.6.4 A VMS shall be provided on every other ATM installation, alternating with SMS. Installations containing SMS shall not contain a VMS.
- 5.3.6.5 At an installation, the VMS shall be mounted on the same structure as the adjacent LCS.
- 5.3.6.6 At an installation, the horizontal distance between the VMS and the nearest LCS shall be no more than 5 feet.
- 5.3.6.7 At an installation, the VMS may be located above the LCS (this will require structural design).

### 5.3.7 ATM full-size VMS specification

- 5.3.7.1 The VMS legend shall be full-matrix, full-color LED, capable of displaying 3 lines of text.
- 5.3.7.2 For signs with fixed character width, each line shall contain 18 characters.
- 5.3.7.3 For signs with variable character width, each line shall contain at least 21 characters.
- 5.3.7.4 The character set shall be capable of displaying characters from 20 (hex) to 7E (hex), inclusive, of the ASCII character set.
- 5.3.7.5 The character height shall be 18 inches.
- 5.3.7.6 The sign shall be capable of displaying graphics, symbols and any font set.

### 5.3.8 ATM small VMS specification

- 5.3.8.1 The VMS legend shall be full-matrix, full-color LED, capable of displaying 3 lines of text.
- 5.3.8.2 For signs with fixed character width, each line shall contain 14 characters.
- 5.3.8.3 For signs with variable character width, each line shall contain at least 14 characters.
- 5.3.8.4 The character set shall be capable of displaying characters from 20(hex) to 7E(hex), inclusive, of the ASCII character set.
- 5.3.8.5 The character height shall be 18 inches.
- 5.3.8.6 The sign shall be capable of displaying graphics, symbols and any font set.

## 6 Other ITS devices

---

### 6.1 HAR

#### 6.1.1 General

6.1.1.1 The radio frequency stated on the HAR sign shall match the broadcast frequency of the associated HAR transmitter.

#### 6.1.2 HAR sign (HARS) location

6.1.2.1 HAR signs shall be located 1 to 2 miles in advance of the corresponding HAR transmitter. For HAR transmitters located within an interchange, this distance shall be measured from the beginning of the furthest exit ramp of the interchange.

6.1.2.2 HAR signs shall be mounted on a sign structure over the freeway lanes if the roadway contains 3 or more lanes in the same direction of travel.

6.1.2.3 If the roadway contains fewer than 3 lanes in the same direction of travel, HAR signs may be mounted on the shoulder.

#### 6.1.3 HAR transmitter (HART) location

6.1.3.1 The transmitter shall be placed in or near major interchanges.

6.1.3.2 The transmitter shall be placed on a hill or at a location with open space surrounding the transmitter in order to ensure high transmission quality.

#### 6.1.4 Cabinet

6.1.4.1 HAR signs and transmitters shall utilize a ground-mounted 331-style cabinet.

6.1.4.2 The cabinet shall be located where a person performing work from the cabinet (facing the display panel) can see the face of the HAR sign and beacons.

### 6.2 Environmental Sensor Station (ESS)

Environmental sensor stations are used to measure, report and forecast road-related weather conditions. The information is especially valuable in the winter and allows WSDOT maintenance personnel to make timely winter maintenance decisions, such as proactive snow and ice control. The information is also provided to the public as traveler information. The ESS is also known as a "weather station" or "RWIS".

**6.2.1 Location**

6.2.1.1 The location of the ESS shall be determined by the NWR Area Maintenance Supervisor.

6.2.1.2 The pavement sensor shall be in the outside lane, 4 feet from the edge stripe.

**6.2.2 Cabinet**

6.2.2.1 The ESS shall utilize a ground-mounted 331-style cabinet.

**6.3 Uninterruptable Power Supply (UPS)**

Uninterruptable power supply devices are used to provide backup power to specific devices in the event of a power outage or other interruption of utility power. UPS are typically installed in support of intersection traffic signal cabinet, but may also be used for other applications such as VMS, communication Hubs, part-time use shoulder lane (PUSL) signage, etc.

**6.3.1 Conduit**

6.3.1.1 In addition to any power supply or distribution conduits, a dedicated 2" conduit containing an outside plant (OSP) Cat 6 cable is required between the UPS cabinet and the nearest cabinet containing the pre-terminated patch panel and Ethernet switch to provide communications to the UPS controller.

# 7 Temporary ITS

---

## 7.1 Overview

During construction work, it may be necessary to temporarily relocate or modify ITS equipment in the field to maintain operations. The designer must keep in mind that effective ITS operation is crucial to the efficiency of the WSDOT roadway network. Traffic management is ultimately dependent on equipment that is available, functional and reliable. Any degradation to ITS equipment may have system-wide consequences. For example, a ramp meter site using faulty traffic data may become a traffic flow bottle-neck for an entire corridor, while failed CCTV equipment may reduce emergency response times.

Therefore, it is important that ITS equipment remain reliably functional throughout the construction process and, if necessary, temporary ITS equipment be used to maintain high levels of operation.

## 7.2 General

### 7.2.1 Operations

7.2.1.1 The designer shall consider the impacts of the construction process on ITS devices, power, communication and other conduit/wiring systems of ITS devices. The designer shall design a temporary system as a substitute if the original system will be impacted.

7.2.1.2 ITS devices shall remain operational at all times, unless specified otherwise by the contract documents.

7.2.1.3 The designer shall exercise caution to avoid unintentionally damaging ITS devices during the construction process, especially when grading, saw cutting, grinding, excavating, performing drainage work, shifting lanes, etc. The designer should coordinate with those from other disciplines to flag items on the plan sheets that must be avoided. This may include a note to avoid saw cutting loops or digging into conduits.

## 7.3 Communication systems

### 7.3.1 Exposure to traffic

7.3.1.1 Temporary lane striping shall not route traffic over existing junction boxes or vaults without approval from a WSDOT structural engineer.

7.3.1.2 Junction boxes and vault lids that will be exposed to traffic shall be replaced with heavy-duty boxes before exposure to traffic.

## 7.4 CCTV

### 7.4.1 Coverage during construction

- 7.4.1.1 Cameras shall remain operational during construction.
- 7.4.1.2 Cameras to be impacted by construction activities shall be replaced, before work begins, by temporary cameras or permanent cameras in new locations.
- 7.4.1.3 Cameras that remain in operation shall provide 100 percent coverage on all freeways and ramps throughout the life of the project.

## 7.5 Ramp meters

### 7.5.1 Operations

- 7.5.1.1 Ramp meters shall remain operational during construction.
- 7.5.1.2 The designer may relocate signal heads and provide temporary detectors if needed to accommodate the construction process.
- 7.5.1.3 Advance warning signs and beacons shall remain visible and operational.
- 7.5.1.4 All signing for ramp meters shall remain visible to motorists during construction and meet WSDOT signing standards.

## 7.6 Temporary vehicle detection

### 7.6.1 Type and location

- 7.6.1.1 Temporary detection shall be provided for all mainline lanes and all ramps during construction if the original equipment is removed from service or can no longer function reliably.
- 7.6.1.2 Temporary detection on the mainline, off-ramps and non-metered on-ramps shall be within 200 feet of the original equipment they are substituting. They shall also meet the requirements for loop spacing.
- 7.6.1.3 Sites equipped with ramp meter systems which require temporary detection shall use embedded induction loops in accordance with the ITS details.
- 7.6.1.4 Temporary detection shall be calibrated to provide comparable availability, detection quality (within 5%) and reliability as the device it is substituting.

# 8 Communications

---

## 8.1 Overview

The communications network provides the backbone for all Intelligent Transportation Systems (ITS) operations. It is the crucial link that connects not only the ITS devices in the field, but also the traffic management systems and software.

WSDOT relies on Intelligent Transportation Systems to provide the necessary traffic management strategies, and in turn depends heavily on the communications network. The availability, reliability and efficiency of the communications network influence the effectiveness of traffic management strategies. For example, a slow network may delay the timeliness of updating traffic control messages on variable message signs and lane control signs, affecting the credibility of the information displayed. Repeated over time, this may erode the public's trust in WSDOT's ability to provide timely and accurate information to road users.

An unreliable network may cause communications outages that bring ITS devices offline for entire corridors at a time. This may affect operations such as ramp metering, which will have to rely on time-of-day settings rather than real-time data. Since time-of-day settings are static, they cannot reflect actual traffic conditions and may cause the ramp meter to release vehicles at inefficient rates.

To maintain a high standard of design, this document provides the requirements and guidelines necessary for ensuring that WSDOT's communications network is available, functional and reliable.

## 8.2 Communication hub

### 8.2.1 Description

A communications hub is a facility in the field that handles ITS devices and communications equipment for an area. There are 15 hubs in the WSDOT network as of this writing, providing services such as video transmission, video distribution, data transmission and data distribution. New hubs should be considered in projects that expand the footprint of the existing ITS network.

### 8.2.2 Location

8.2.2.1 The location of the hub shall be determined by the NWR ITS Engineer. Generally, a hub is provided at major freeway-to-freeway interchanges and also every 10-15 miles along a corridor.

### 8.2.3 Existing communication hubs

8.2.3.1 Existing communications hubs within the project limits shall be replaced if any of the following conditions are met:

- Identified for replacement in the contract documents;
- The communications hub is more than 20 years old before physical completion of the contract.

### 8.2.4 Exterior treatment

8.2.4.1 The area around the hub shall be prepared and fenced in accordance with the NWR ITS details.

## 8.3 Conduit

### 8.3.1 Location

8.3.1.1 Mainline conduits shall stay on the same longitudinal alignment as long as possible (1 mile minimum). By maintaining a longitudinal alignment, cable installation can be simplified. The total length of the cable can also be shortened, as less cabling is used to travel across the roadway. Most importantly, this increases design consistency and predictability during road construction, which will reduce the chance of unintentional impacts and aids in future locating of buried conduit.

8.3.1.2 If installed near noise walls or right-of-way (ROW) fences, the mainline conduits shall be located on the freeway side of any noise walls or ROW fences. This improves access and avoids special access arrangements that may delay repairs.

8.3.1.3 Mainline conduits shall be located to accommodate future roadway widening projects.

8.3.1.4 All raceways in the mainline conduits shall be continuous from HUB to HUB (or end to end).

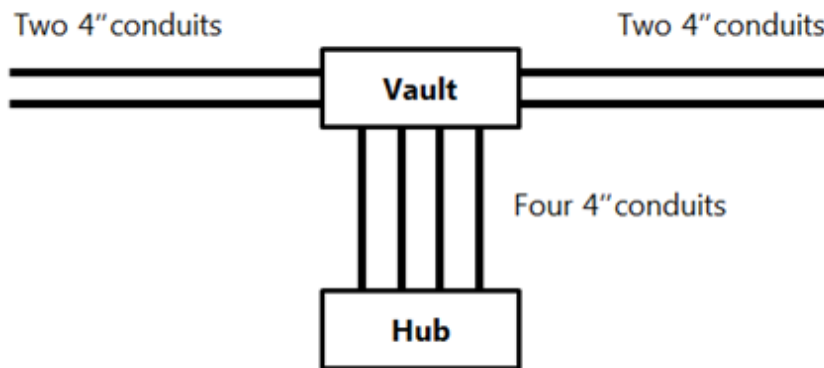

**Figure 8-1: Raceways**

8.3.1.5 If conduits containing fiber optic cables are attached to a bridge, these conduits shall be installed at a higher elevation than the top of the pull boxes or cable vaults at both ends of the crossing. This is to prevent water from being trapped in the conduits. Trapped water in the winter may freeze, expand and damage the fiber optic cables in the conduit, resulting in costly repairs and lengthy network outages.

8.3.1.6 If conduits containing fiber optic cables are attached to a bridge, the pull boxes or cable vaults at both ends of the crossing shall contain drains.

8.3.1.7 Any exposed conduits containing fiber optic cables shall be designed with these minimum characteristics:

- A pull box or cable vault shall be located within 50 feet of both ends of the exposed conduit;
- The exposed conduit shall be at a higher elevation than the top of the pull box or cable vault at either end;
- The pull box or cable vault at both ends of the exposed conduit shall include a 2-inch screened drain.

### Acceptable design

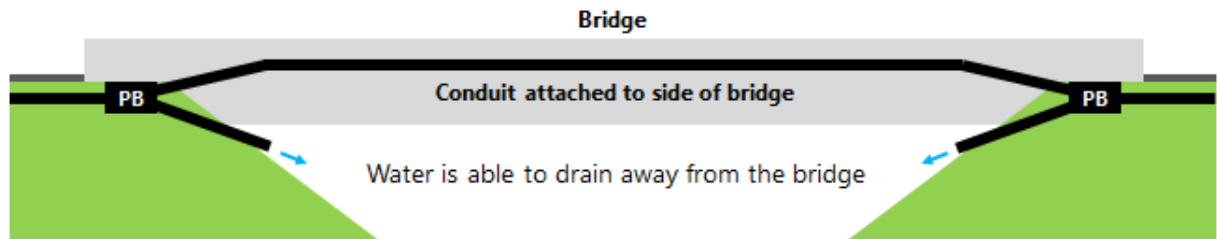

### Acceptable design

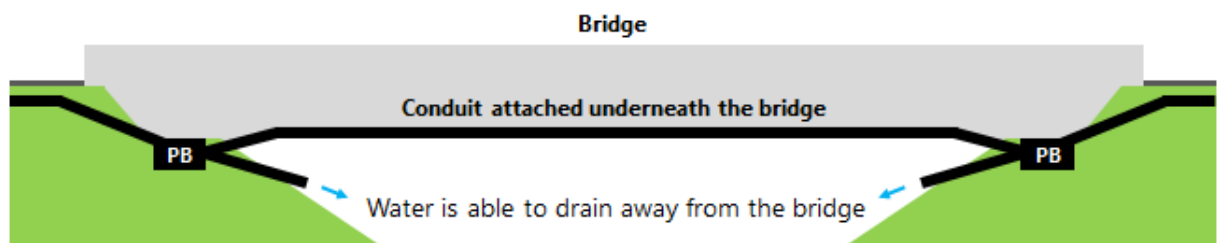

### Unacceptable design

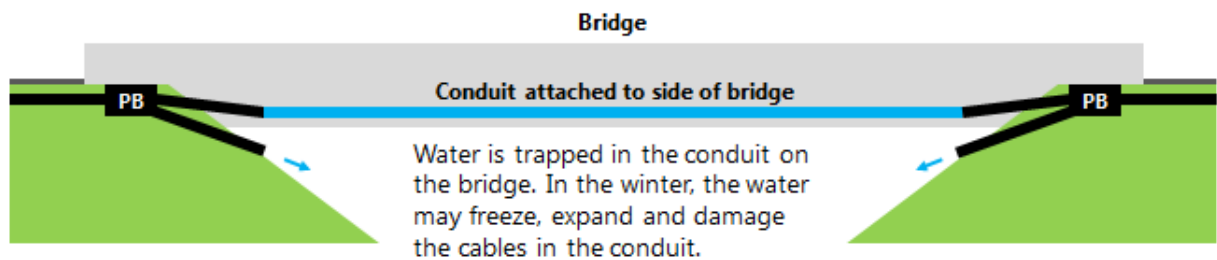

**PB** Pull box

**Figure 8-2: Drainage considerations for conduits on bridges**

- 8.3.2 Size
  - 8.3.2.1 Along freeways, the mainline conduit system shall consist of two 4-inch conduits. Each 4-inch conduit shall contain 4 innerducts.
  - 8.3.2.2 Along non-freeway roadways, the mainline conduit system shall consist of two 2-inch conduits or larger.

8.3.3 Contents of conduits

8.3.3.1 Conduits with innerducts shall only contain mainline and distribution communication cables.

8.3.3.2 Systems with more than one mainline conduit shall have the mainline fiber and the distribution fiber located in separate conduits (outerduct).

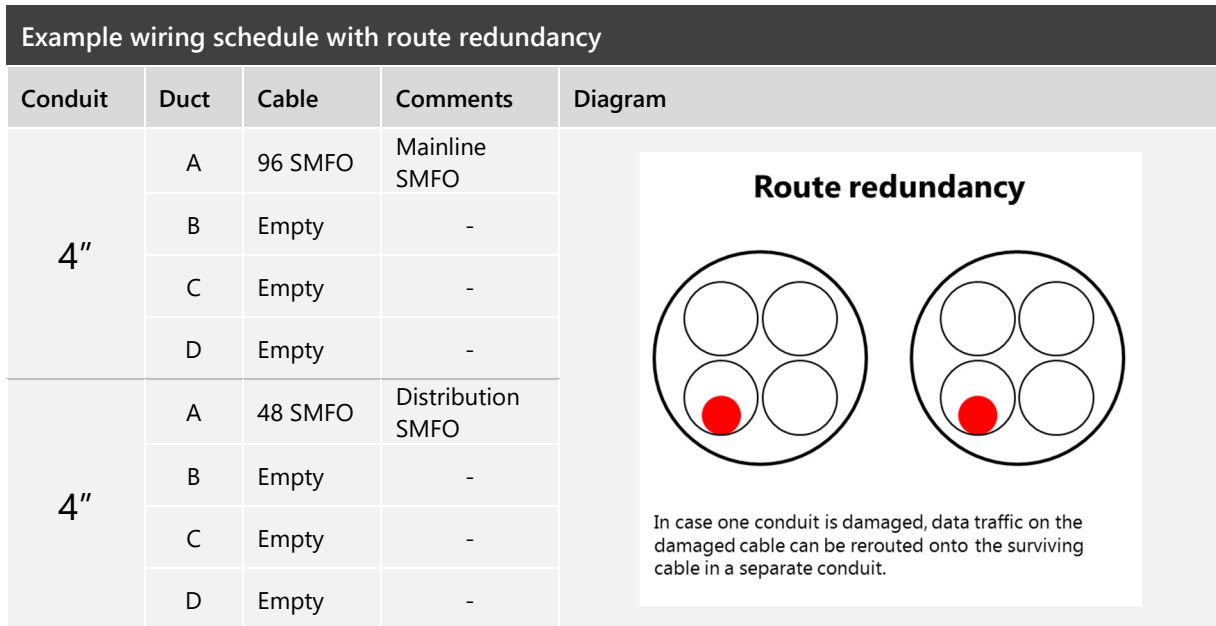

Figure 8-3: Redundant wiring schedule

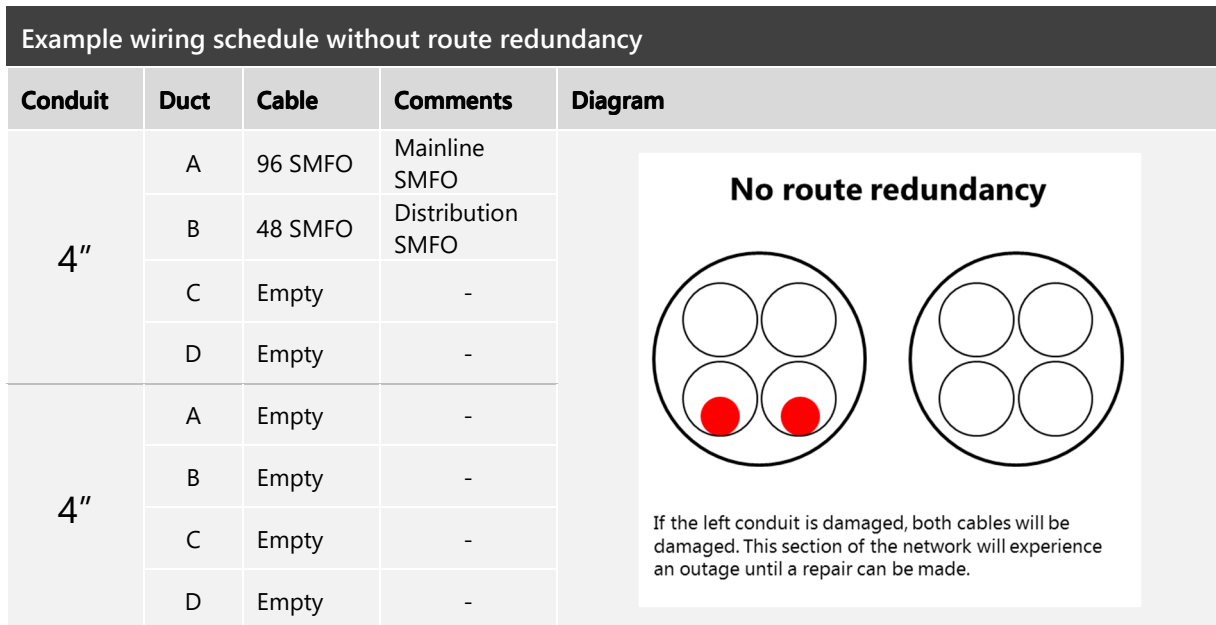

Figure 8-4: Non-redundant wiring schedule

**8.3.4 Existing infrastructure**

8.3.4.1 When modifying existing mainline conduit, or when the existing mainline conduit will be impacted, any conduit that does not meet current NWR ITS standards (material, size, inner-duct quantity, etc.) shall be replaced with new conduit between pull boxes/cable vaults.

8.3.4.2 Conduit repair kits of any kind shall not be used, as most repair kits are not capable of reliably withstanding conditions experienced during roadway applications.

8.3.4.3 If a roadway is modified so that an existing conduit ends up located under a travel lane, the existing conduit shall be replaced (from existing vault to existing vault) in a location outside of the paved area (or under the new shoulder if no other location is feasible).

**Conduit repair kit failures**

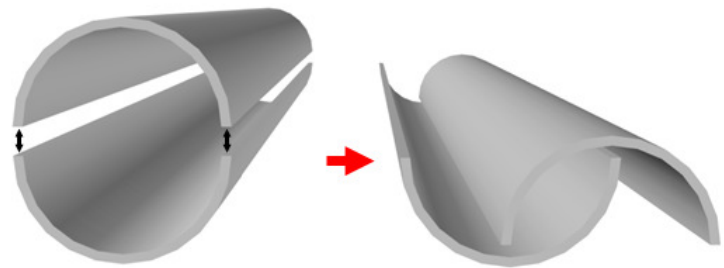

Conduit repair kits tend to collapse under the stresses incurred from the roadway, heavy machinery, the weight of the soil, etc. The location of damaged sections of conduit are difficult to isolate and may require traffic control, resulting in high costs throughout the replacement process.

**Figure 8-5: Conduit repair kit failures**

### 8.3.5 Crossings

8.3.5.1 Any conduit crossing used to carry the distribution cable between the mainline conduit system and an ITS cabinet shall not be more than 500 feet from that ITS cabinet.

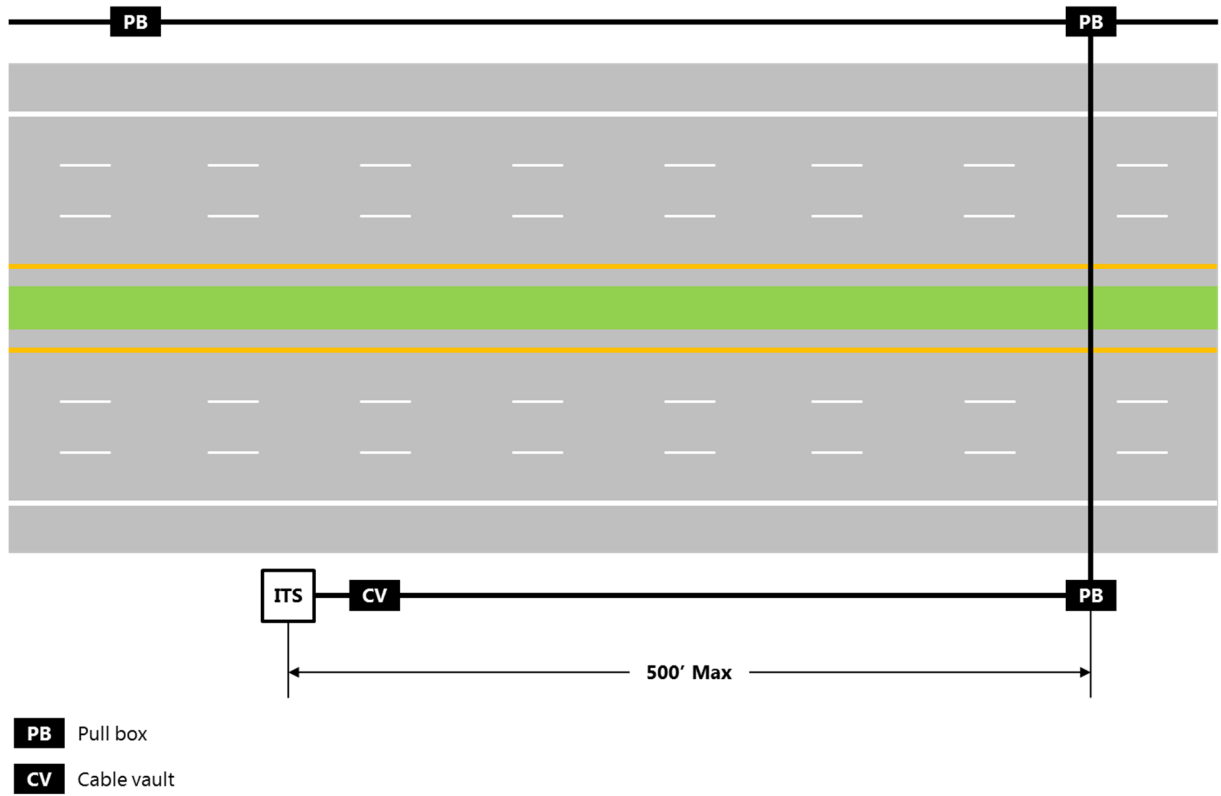

**Figure 8-6: Conduit crossings**

## 8.4 Vaults

### 8.4.1 General requirements

8.4.1.1 Cable vaults and pull boxes that are part of the mainline conduit system shall only contain the mainline and distribution communication cables, except where directly connected to ITS device cabinets.

### 8.4.2 Cable vaults

8.4.2.1 Cable vaults are required at the following locations:

- Any underground fiber optic splice location, including known future splice locations;
- All new and existing communication hubs;
- All new and existing ITS, tolling and signal cabinet locations;
- Every mile along the mainline conduit run.

8.4.2.2 A screened 2-inch drain pipe shall be provided between all cable vaults and any drainage ditch, swale or pond within 100 feet (see ITS detail).

### 8.4.3 Pull boxes

8.4.3.1 Pull boxes shall be located along fiber optic conduit runs with no more than 1000 foot spacing.

8.4.3.2 Pull boxes shall be located at both ends of crossings, borings and bridges.

8.4.3.3 No junction box smaller than a pull box shall be used in any conduit run containing fiber optic cable(s).

8.4.3.4 A screened, 2-inch drain pipe shall be provided between all pull boxes and any drainage ditch, swale or pond within 100 feet.

### 8.4.4 Small cable vaults

8.4.4.1 Small cable vaults are non-standard vaults and are intended to be used exclusively to contain a fiber optic splice closure. Typical applications of this vault are for arterial signal interconnect and retrofits of legacy communication infrastructure. The use of a small cable vault requires approval from the NWR ITS Engineer.

8.4.4.2 Small cable vaults shall not be used in the following locations:

- Anywhere along the mainline conduit system (conduits with innerducts);
- With conduits containing cables other than fiber optic cables;
- Where more than 4 conduits will enter the vault.
- Any new ITS cabinet installation in a limited-access facility.

8.4.4.3 All conduits entering a small cable vault shall be installed in the short end walls.

8.4.4.4 A screened, 2-inch drain pipe shall be provided between all small cable vaults and any drainage ditch, swale or pond within 100 feet.

## 8.5 Mainline cabling

### 8.5.1 Description

8.5.1.1 The mainline cable is defined as the longitudinal fiber optic cable running along the corridor between communication hubs in the mainline communication conduit system.

### 8.5.2 General requirements

8.5.2.1 Splices are allowed every 13,000 to 18,000 feet in locations determined by the NWR ITS engineer. For maintenance reasons, it is important that splice locations are accessible with a truck and a splicing trailer.

8.5.2.2 If the existing mainline cable will be impacted, the cable shall be replaced between existing splices (no new splices shall be added).

8.5.2.3 The cable strand count shall be determined by the NWR ITS Engineer. The cable is typically a 48 to 96 count single-mode cable.

### 8.5.3 Cable termination

8.5.3.1 Pre-terminated (preterm) patch panels meeting the current WSDOT specifications shall be installed at all locations with a mainline cable interface.

8.5.3.2 The preterm cable shall be spliced to the mainline cable in a cable vault or optical cable entrance facility (OCEF) located no more than 100 feet from the cabinet or hub containing the preterm panel.

8.5.3.3 There shall be one pre-terminated patch panel for each optical cable installed in a hub or fiber terminal cabinet (FTC).

8.5.3.4 The mainline and the distribution cables shall be spliced to separate pre-terminated patch panels where both are terminated in a single cabinet.

8.5.3.5 There shall be one fiber optic splice closure per fiber optic stub cable.

8.5.3.6 If the mainline cable ends at a location other than the hub, the cable shall be spliced to a pre-terminated patch panel installed in the ITS cabinet (not ES cabinet) nearest the physical end of the project.

## 8.6 Distribution cabling

### 8.6.1 Description

8.6.1.1 The distribution cable, also known as “mainline distribution”, is defined as the fiber optic cable that connects the roadside ITS and tolling cabinets to the nearest hub.

### 8.6.2 General requirements

8.6.2.1 Distribution cabling shall use the mainline communication conduit system for all longitudinal runs along the corridor.

8.6.2.2 If an existing distribution cable will be impacted by the project, the cable shall be replaced between devices currently served by the cable.

8.6.2.3 If an existing cabinet served by the distribution cable is removed from service, the existing distribution cable shall be replaced between the nearest remaining device in each direction of the cable.

8.6.2.4 The cable strand count shall be determined by the NWR ITS Engineer. The cable is typically a 36 to 48 count single-mode cable.

### 8.6.3 Strand usage

8.6.3.1 The first 12 strands in both directions are terminated at all ITS cabinets served by the cable.

8.6.3.2 Unique strands in both directions shall be terminated at each tolling cabinet and at each toll rate sign cabinet. The strand numbers and quantity shall be determined by the NWR ITS Engineer.

8.6.3.3 Additional strands in both directions shall be terminated for agency interface. The strand numbers, quantity and location shall be determined by the NWR ITS Engineer.

8.6.3.4 Additional strands in both directions shall be terminated for network redundancy. The strand numbers, quantity and location shall be determined by the NWR ITS Engineer.

### 8.6.4 Route architecture

8.6.4.1 The distribution cable shall connect to all ITS cabinets and intersection signal cabinets.

8.6.4.2 The distribution cable shall be routed to cabinets in order of the milepost of the cabinet location (not the device ID).

8.6.4.3 When ITS cabinets are grouped on a shared foundation, the distribution cable shall connect to only one of the cabinets in the following order of priority:

1. Fiber Optic Terminal Cabinet (FTC)
2. ATM cabinet
3. CCTV cabinet
4. HARS cabinet
5. VMS cabinet
6. Other ITS cabinet
7. ES Cabinet

- 8. UPS cabinet (331-style)
- 9. Intersection signal cabinet

- 8.6.4.4 Tolling cabinets and toll rate sign cabinets shall have their own connection to the distribution cable, independent of any connection to adjacent ITS cabinets.
- 8.6.4.5 Cabinets that share a foundation and do not contain a patch panel shall each have an OSP CAT 6 cable routed through the conduits in the foundation to the cabinet containing the patch panel. In this case, the Ethernet switch(es) shall be installed in the cabinet with the patch panel. The Cat 6 cable may only share conduit with other Cat 6 cables or with fiber optic cables.

**8.6.5 Cable termination**

The following requirements are to ensure maximum uptime of the network. By separating certain cables and panels, they can be taken offline for maintenance without impacting other parts of the network.

- 8.6.5.1 Pre-terminated (preterm) patch panels meeting the current WSDOT specifications shall be installed in all locations with a distribution cable interface.
- 8.6.5.2 There shall be a maximum of one pre-terminated patch panel in each cabinet except where an outside agency's fiber is terminated in a WSDOT cabinet. In that case, there shall be two pre-terminated panels.
- 8.6.5.3 There shall be one pre-terminated patch panel for each optical cable installed in a hub or building/facility. The exception is when both cables are on the same roadway, in which case distribution cables may be combined into one panel (i.e. I-5 northbound and southbound distribution cables may be spliced to the same panel).
- 8.6.5.4 The pre-terminated cable shall be spliced to the distribution cables in a cable vault or optical cable entrance facility (OCEF) located no more than 100 feet from the cabinet or hub containing the pre-terminated panel.

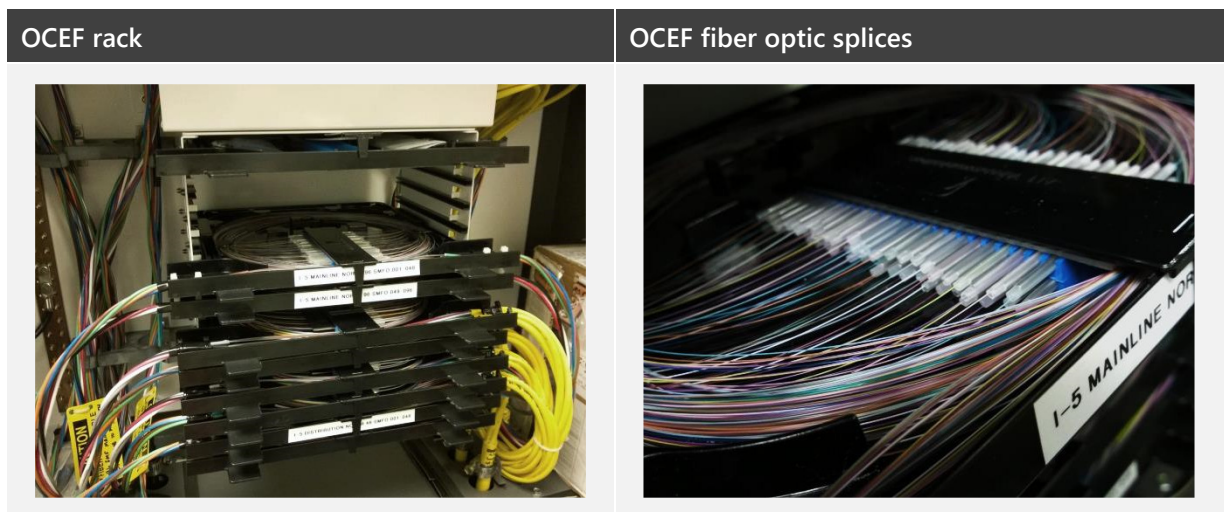

**Figure 8-7: Optical cable entrance facility (OCEF)**

- 8.6.5.5 There shall be one fiber optic splice closure per pre-terminated stub cable except where the pre-terminated patch panels for a tolling cabinet and an ITS cabinet are spliced in the same cable vault. In this case, there shall be no more than two pre-terminated stub cables connected to one fiber optic splice closure; one for ITS and one for tolling.

## 8.7 Lateral cabling

### 8.7.1 Description

Lateral cabling is defined as a fiber optic cable spur between one ITS cabinet served by the distribution cable and one non-ITS cabinet, or between one ITS cabinet served by the distribution cable and one signal cabinet.

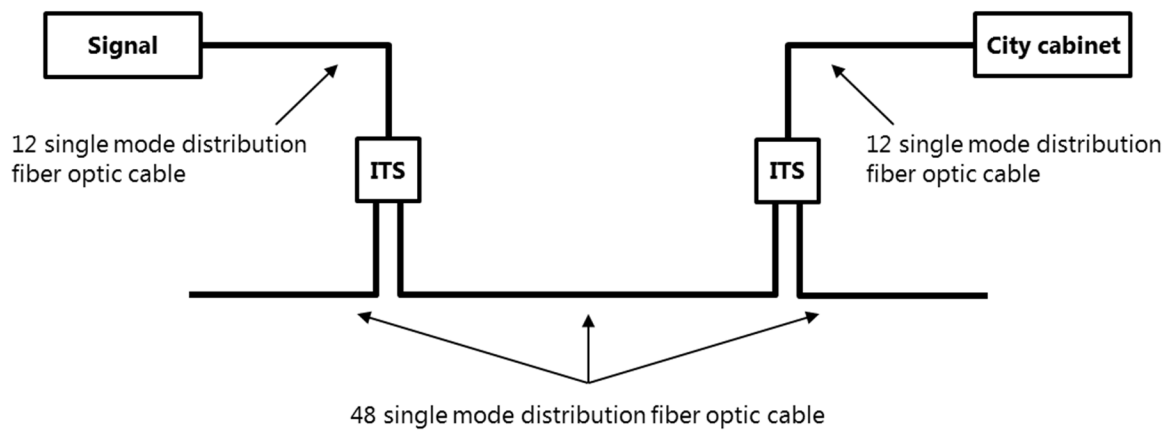

Figure 8-8: Lateral cabling

### 8.7.2 General requirements

- 8.7.2.1 Lateral cabling may be used to connect non-ITS devices or signal cabinets located within 750 feet of an ITS cabinet served by the distribution cable when approved by the NWR ITS Engineer.
- 8.7.2.2 Any device cabinet served by the distribution cable shall utilize no more than 1 lateral cable.
- 8.7.2.3 Any non-ITS cabinet or signal cabinet shall utilize no more than 2 lateral cables.
- 8.7.2.4 The lateral cable is typically a 12 count single-mode cable.

### 8.7.3 Cable termination

- 8.7.3.1 Pre-terminated (preterm) patch panels meeting the current WSDOT specifications shall be installed in all locations with a lateral cable interface.
- 8.7.3.2 There shall be a maximum of one pre-terminated patch panel in each cabinet except where an outside agency's fiber is terminated in a WSDOT cabinet. In that case, there shall be two pre-terminated panels; one for WSDOT and one for the outside agency.
- 8.7.3.3 Lateral fiber cables shall be spliced to a pre-terminated patch panel. The pre-terminated patch panel shall be combined with all other lateral fibers and interconnect fibers going to that location. If room allows, it shall also be combined with the distribution cable.
- 8.7.3.4 The pre-terminated stub shall be spliced to the lateral cables in a cable vault or optical cable entrance facility (OCEF) located no more than 100 feet from the cabinet or hub containing the pre-terminated panel.
- 8.7.3.5 There shall be one fiber optic splice closure per pre-terminated stub cable.

## 8.8 Interconnect cabling

### 8.8.1 Description

8.8.1.1 The interconnect cable is defined as a distribution-style fiber optic cable connecting signal cabinets and other ITS devices along an arterial state highway.

### 8.8.2 General

8.8.2.1 Interconnect cables shall meet the same design requirements as fiber optic distribution cables.

### 8.8.3 Cable termination

8.8.3.1 Pre-terminated (preterm) patch panels meeting the current WSDOT specifications shall be installed at all locations where there is an interconnect cable interface.

8.8.3.2 There shall be a maximum of one pre-terminated patch panel in each cabinet except where an outside agency's fiber is terminated in a WSDOT cabinet. In that case, there shall be two pre-terminated panels.

8.8.3.3 Interconnect fiber cables shall be spliced to a pre-terminated patch panel. The pre-terminated patch panel shall be combined with all other interconnect fibers and lateral fibers going to that location. If room allows, it shall also be combined with a distribution cable.

8.8.3.4 The pre-terminated stub shall be spliced to the interconnect cables in a cable vault or optical cable entrance facility (OCEF) located no more than 100 feet from the cabinet or hub containing the pre-terminated panel.

8.8.3.5 There shall be one fiber optic splice closure per pre-terminated stub cable.

## 8.9 Fiber optic patch cords

### 8.9.1 General requirements

8.9.1.1 Patch cords contained within a patch panel shall be no more than 1 foot longer than required to make the connection.

8.9.1.2 Patch cords between two patch panels shall be no more than 1 foot longer than required to make the connection.

8.9.1.3 Patch cords between a patch panel and a device shall not be more than 2 feet longer than required to make the connection.

8.9.1.4 Patch cords between a patch panel and a device shall be contained inside of a 1/2" to 5/8" yellow split loom.

8.9.1.5 Boots shall be glued to the patch cord jacket to prevent spinning or from being pulled off under normal use.

## 8.10 Other requirements for cabling

### 8.10.1 General requirements

- 8.10.1.1 Communication cables shall not occupy the same conduits or junction boxes as power conductors.
- 8.10.1.2 A single splice closure shall contain no more than one pre-terminated stub unless approved by the NWR ITS Engineer.
- 8.10.1.3 Mainline cable splices and distribution cable splices shall not occur in the same splice closure.
- 8.10.1.4 Only 48-port and larger pre-terminated panels shall be installed in any hub.
- 8.10.1.5 Pre-terminated patch panels shall be used for all fiber optic terminations in all locations. Distribution panels and directly connectorized fibers are not allowed.
- 8.10.1.6 Mechanical splices or fiber optic strands shall not be used.

## 8.11 Communications Equipment

### 8.11.1 Roadside cabinets

At a minimum, the listed communication equipment and accessories (including all mounting hardware and cabling to provide a fully functional system) shall be installed in each of the following types of cabinets (both new and existing).

A standalone cabinet is defined as a cabinet that (1) does not share a common foundation with another ITS cabinet and (2) is not located within 300 feet of another ITS cabinet.

8.11.1.1 At each ES cabinet, the following shall be installed:

- One RuggedCom RS900 switch located in the cabinet with the pre-terminated patch panel;
- One RuggedCom RMC30 terminal server if the ES utilizes a 170 controller.

8.11.1.2 At each HARS cabinet, the following shall be installed:

- One RuggedCom RS900 switch located in the cabinet with the pre-terminated patch panel;
- One RuggedCom RMC30 terminal server if the HARS utilizes a 170 controller.

8.11.1.3 At each ATM cabinet, the following shall be installed:

- One RuggedCom RS900 switch for up to 5 Ethernet connections;
- One RuggedCom RSG2300 switch for 6 or more Ethernet connections;

8.11.1.4 At each PTR cabinet, the following shall be installed:

- One RuggedCom RS900 switch;
- One Moxa 5210T Terminal Server.

8.11.1.5 At each VMS and TRS cabinet, the following shall be installed:

- One RuggedCom RS900 switch.

8.11.1.6 At each traffic signal cabinet, the following shall be installed:

- One RuggedCom RS900 switch (Note: If the signal cabinet is utilizing a lateral cable, the RS900 in the ITS cabinet nearest to the signal cabinet shall contain 3 optical ports).

8.11.1.7 At each HAR transmitter cabinet, the following shall be installed:

- One RuggedCom RS900 switch;
- One Quintum 2-channel FXS VoIP device.

8.11.1.8 At each ESS (weather station) cabinet, the following shall be installed:

- One RuggedCom RS900 switch.

8.11.1.9 At each CCTV cabinet, or any cabinet with a camera connected to it, the following shall be installed:

- One RuggedCom RS900G switch.

## 8.11.2 Communication hubs

At a minimum, each hub (both new and existing) shall receive the following communication equipment and accessories (including all mounting hardware and cabling to provide a fully functional system):

8.11.2.1 Data system

- One 19-inch wide Ethernet switch mounting bracket (see ITS details) for every 5 switches, or part thereof;
- One RuggedCom RS900 switch for each network (ITS, Tolling, etc.) in each direction of all state highways served by the hub;
- One RuggedCom RSG910C switch with two 25km SFP's for the camera network in each direction of all state highways served by the hub.

### 8.11.3 Traffic management center

At a minimum, traffic management centers (TMC) shall receive all equipment necessary to support the new field equipment, the existing equipment required to remain and communication hub equipment (including all mounting hardware and cabling to provide a fully functional system).

#### 8.11.3.1 TMC equipment shall include, but is not limited to:

- Ethernet switches for ITS and camera networks
- 24-channel FXO VoIP device
- Any other office-side equipment needed for a complete system

# 9 ITS for roundabouts

---

## 9.1 CCTV

### 9.1.1 Location

- 9.1.1.1 A pan-, tilt- and zoom-capable camera shall be installed near the roundabout in a location that provides a view of all legs (entrances and exits) of the roundabout. The camera shall be located to maximize the view of each leg, but priority should be given to those legs that are part of the state highway. Optimally, the camera shall be located approximately 400-600 feet from the center of the roundabout along the state highway. The camera view shall show all movements within the roundabout without having to pan the camera.

## 9.2 Loop detection

### 9.2.1 Data station

- 9.2.1.1 A data station shall be provided near the roundabout.

### 9.2.2 Loops on entering lanes

- 9.2.2.1 Loops shall be provided on all lanes entering the roundabout. They shall be located upstream of the roundabout (before entering the roundabout).
- 9.2.2.2 Loops shall be located approximately halfway between the beginning of the multilane section and the yield line, but downstream from the beginning of the splitter island.
- 9.2.2.3 Loops shall be upstream of any crosswalks.
- 9.2.2.4 For short splitter islands, loops shall be located near the beginning of the island. For long splitter islands, loops shall be located near the midpoint of the island.

### 9.2.3 Loops on exit lanes

- 9.2.3.1 Loops shall be provided on all lanes exiting the roundabout. They shall be located downstream of the roundabout (after exiting the roundabout).
- 9.2.3.2 Loops shall be located approximately halfway between the roundabout and the lane reduction (where applicable), but upstream of the end of the splitter island.
- 9.2.3.3 Loops shall be downstream of any crosswalks.
- 9.2.3.4 For short splitter islands, loops shall be located near the end of the island. For long splitter island, loops shall be located near the midpoint of the island.

## 9.3 Communication

### 9.3.1 Connection to WSDOT network

- 9.3.1.1 A communication link that includes conduit(s) and fiber optic cables to the nearest existing WSDOT fiber optic network shall be provided. If this is not possible, a leased broadband drop shall be used instead.

9.3.1.2 All other necessary communication hardware required for a fully-functional system shall be provided.

## 9.4 ITS configuration

### 9.4.1 Naming and location

9.4.1.1 Loop detection and CCTV shall be placed in accordance with the detail shown in **Figure 9-1: Loop naming scheme for roundabouts**.

9.4.1.2 Loop naming shall follow the scheme shown in **Figure 9-1: Loop naming scheme for roundabouts**.

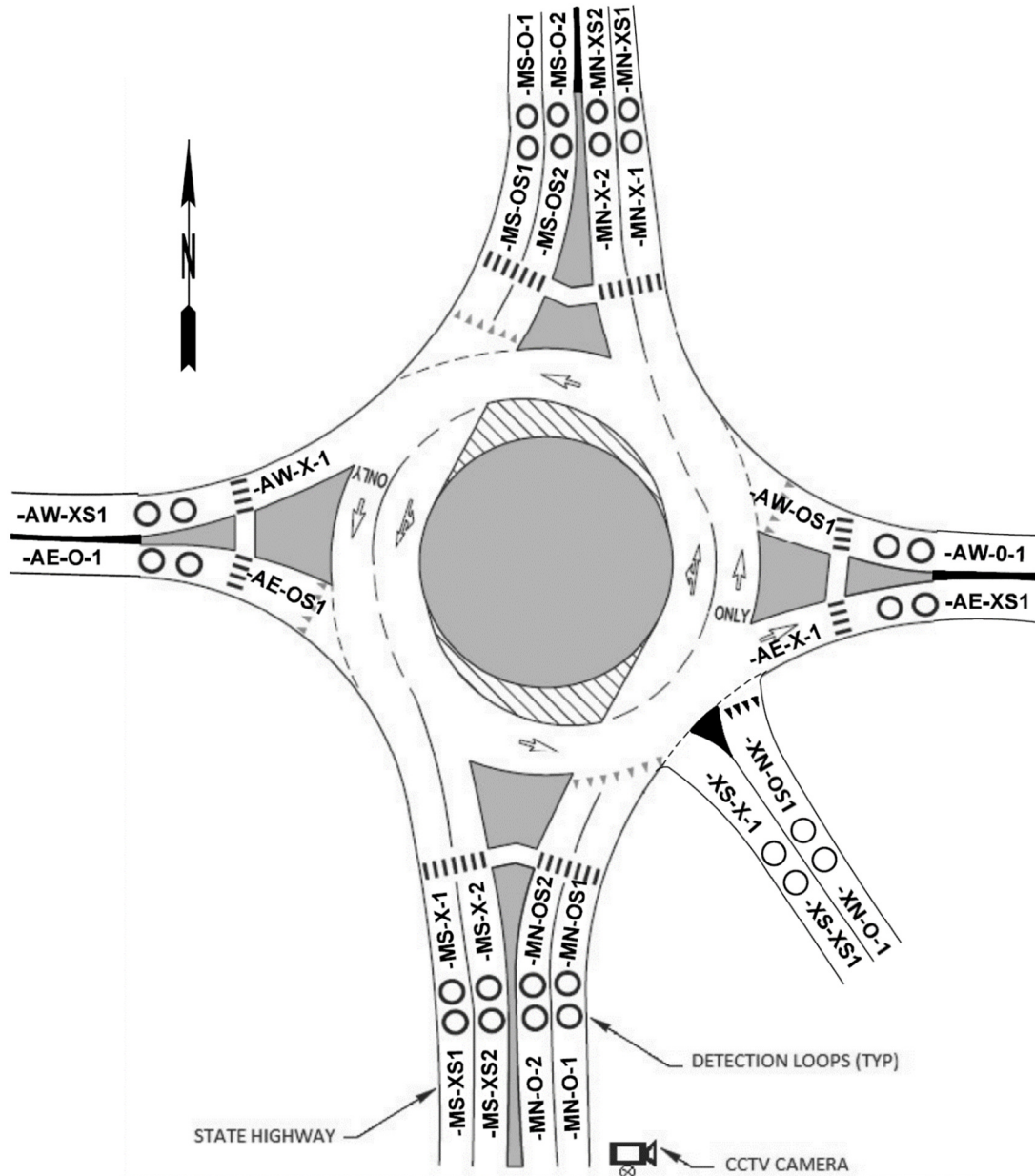

Figure 9-1: Loop naming scheme for roundabouts

## WSDOT NWR Ramp Meter Design Policy Guidance

WSDOT's Northwest Region has a long history of implementing and operating effective, innovative freeway Intelligent Transportation System (ITS) solutions. Practical solutions approach encourages implementation of more flexible and sustainable transportation improvements, with particular focus on low-cost solutions that enhance system performance. The policy outlined in this document shall supplement the guidance outlined in WSDOT Design Manual (DM) chapter 1410.02(3)(e) and 1410.04(4)(e) for all ramps within WSDOT's Northwest Region (NWR).

All on-ramp lanes along urban freeway corridors, including peak use shoulder lanes, shall have the infrastructure in place to meter all lanes. Installations on freeway ramps located outside of urban areas should also be considered. Geometric elements of a metered ramp design shall follow all WSDOT geometric and taper guidance and standards specified in the DM and Standard Plans. Specific operational elements for each ramp meter location shall be determined on an individual location basis using a practical solutions approach. Site specific considerations include (but are not limited to):

- Ramp meter storage requirements (as outlined in the [ITS Design Requirements](#))
- Existing and future transit use on the ramp
- Available right of way (ROW)
- Ramp terminal intersection channelization
- Operational effect on freeway and local arterial mobility & safety
- Typical duration of meter operation

This policy applies to urban freeway ramps that do not currently have ramp meters, as well as existing ramps operating with non-metered HOV bypass lane(s) or shoulder lanes. For the latter, existing HOV bypasses should be converted to metered lanes. The metered lanes may be designated as general purpose or HOV-only.

It is expected that within programmed I&P projects, communication and community outreach for these changes will be incorporated within the project communication plan. As programmed I&P projects and low-cost operational projects are being considered, coordination is required with local jurisdictions, key stakeholders they have identified, and transit agencies during practical solutions planning, scoping and design phases. In addition, community outreach via the media and other electronic means is encouraged during design and required prior to construction and implementation of the operational change.

Ramps without scheduled transit-related service can have the HOV bypass lane converted to a metered general purpose (GP) lane. For existing ramps with continuing or expected regularly scheduled transit service, a bus-only shoulder bypass lane, or metered HOV lane may be considered if storage requirements are met. Refer to Northwest Region [ITS Design Requirements](#) 4.3.3.3 for minimum storage requirements for metered lane(s). Transit and HOV vehicles utilizing a metered HOV bypass lane will maintain some travel time advantage over the metered GP traffic.

\*Please note that use of a shoulder for metered traffic still requires a Design Analysis per WSDOT DM 1410.04(3)(c).

For unique circumstances where converting an existing HOV bypass to a metered GP lane will hinder scheduled transit service access to the ramp, conversion to a metered HOV bypass lane may be considered. If a metered HOV lane is not feasible because of storage needs, queue spillback, or other factors, these considerations shall be documented in a Traffic Analysis Report, approved by the Region Traffic Engineer.

Approved:

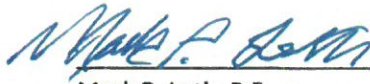
  
\_\_\_\_\_  
Mark P. Leth, P.E.                      8/5/18  
Date

Asst. Region Administrator – Traffic

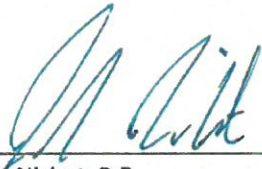
  
\_\_\_\_\_  
John Nisbet, P.E.                      8/2/18  
Date

Director – Traffic Operations

\*Please note that use of a shoulder for metered traffic still requires a Design Analysis per WSDOT DM 1410.04(3)(c).